

2010

CITY OF REGINA

WATER & SEWER UTILITY

AS APPROVED BY CITY COUNCIL



Table of Contents

Letter of Transmittal

Introduction..... 1

Financial Information..... 7

Utility Services

Water..... 23

Wastewater..... 36

Drainage 44

Engineering and Operations Administration 51

Customer Billing and Collection 53

Debt Costs 57

Utility Capital Program

Capital Program Summary 59

Water Supply, Pumping and Distribution 61

Wastewater Collection and Treatment..... 65

Drainage 68

Utility Capital Funding..... 71

Office of the City Manager
February 17, 2010

To: His Worship the Mayor,
and Members of City Council

Re: 2010 – 2014 General Capital Investment Program

Each year City Council is required to adopt operating and capital budgets. There are three components to the budgets, the General Operating Budget, the Water and Sewer Utility Operating and Capital Budget and the General Capital Budget. This document is the Water and Sewer Utility Budget, including the 2010 Utility Operating Budget and the 2010 – 2014 Utility Capital Budget.

Budget Highlights

- Utility rates for 2010 were previously approved by City Council in 2007, when rates were adopted for 2008 through 2010. For an average residential customer, the 2010 rates result in an 8.9% increase or about \$7.71 per month. The increase for a sample commercial customer is 8.7% or about \$49.69 per month.
- The rates approved for 2010 will result in increased revenues of about 9.5%. This reflects a 9% increase in utility rates, the impact of additional customers and an increase in miscellaneous fees such as connection charges. Details on the rates for 2009 through 2010 are provided on pages 15 and 16 of this document.
- The 2010 Utility Operating Budget provides the funding necessary to meet Council's service objectives for water, wastewater and drainage. The total 2010 Operating budget for the Utility, including debt repayment, is about \$55.6 million, an increase of \$3.7 million from the 2009 budget. The main driver of this increase is increased debt servicing costs. Other cost increases include additional costs for the purchase of materials such as pipe, chemicals, electricity and the cost of water from the Buffalo Pound Water Treatment Plant.
- The 2010 – 2014 Utility Capital Program totals \$283 million, with 2010 totaling \$62.1 million. In comparison, the total 2009 – 2013 utility capital program was about \$323.9 million, with 2009's capital spending at \$52.6 million. Major 2010 projects include Wastewater Treatment Plant Expansion (\$5.7 million), System Upgrades for Pressure Zone 2 (\$6.7 million), McCarthy Boulevard Pumping Station Upgrade (\$10.0 million), and the Detention Pond and Storm Trunk to Chuka Creek (\$3.7 million)
- The 2010 – 2014 Capital Program proposes a total of \$162.4 million in debt financing to meet these capital requirements. This debt is made up of \$120 million in new debt in addition to \$42.4 million in debt taken in 2009 for the Global Transportation Hub, to be reassigned to the Utility in 2010. The timing of debt issues will largely depend upon the construction schedule for the wastewater treatment plant.



- Each year an amount is transferred to the General Operating Fund, representing a payment in lieu of taxes and access fee. Any organization or utility operating in a municipality would be required to pay the municipality either property taxes or an access fee for operating rights. Regina's transfer is the total of 7.5% of the previous years budgeted revenues for billed water consumption, wastewater charges and drainage infrastructure levy plus an amount (\$675,000) estimated to be 3/7ths of the GST rebate received by the Utility. This amount is the additional rebate provided by the Federal Government starting in 2004. For 2010, these budgeted amounts total \$5,873,900 which is used for general municipal expenses.

Public Reporting

In 2005, the Province adopted new regulations in Part V.1 of *The Cities Regulations* regarding Public Reporting on Municipal Waterworks. The regulations apply only to waterworks, however since the Utility includes water, wastewater and drainage services, the information required by the regulations is provided for the entire utility. The information requirements include:

- Information on the rate policy and capital investment strategy as adopted pursuant to sections 22.3 and 22.4 of the regulations. The information required with respect to the City's rate policy is provided on pages 13 through 16 of this document. Information on the capital investment strategy is included in the Utility Capital Program Section of this document and in particular, the Infrastructure Overview Section starting on page 57.
- A financial overview providing the information outlined in the regulations. The data outlined in the regulations is included in the Financial Information Section of this document on pages 7 through 10. The regulations also require a comparison of the Utility revenues to expenditures and debt payments, expressed as a ratio in accordance with the following formula:

$$\frac{\text{Revenues}}{\text{(Expenditures + Debt Payments)}}$$

For 2010, based on the definitions in the regulations, the ratio for the Water and Sewer Utility is 1.55, based on revenues of \$77,067,400, expenditures of \$44,251,900 and debt repayments of \$5,506,000. In accordance with the definition in the regulations, expenditures include the interest cost on the debt, while debt payments are the principal repayments on the debt.

For 2010, the ratio indicates that revenues exceed expenditures and debt repayments by about 55%. By policy, the net revenue or surplus is used to fund transfers to the General Operating Fund, with the balance used to fund future Utility capital requirements. This ratio indicates that the Utility is recovering its operating costs as well as providing investment for future capital requirements. The ratio is projected to increase over the next several years as additional funding is generated to pay for the expansion to the wastewater treatment plant.

- Information on the current reserves and deferred revenue, capital plans for infrastructure projects and the sources of funding for the capital projects are detailed in the Utility Capital Program section of this document.

Capital Requirements and Funding

Regina's location, in a sensitive natural environment far from a major water source, impacts on the standards and costs for water supply and wastewater treatment and disposal. Additional information on the regional setting and the implications for Regina is provided in the Introduction Section of this document.

The 2010 Utility Capital Budget totals \$62.1 million with the 2010 – 2014 Utility Capital Budget totaling \$282.6 million over five years. The proposed five-year capital program is approximate \$20 million more than the five-year capital program approved in 2008; an increase of about 8%. While these are

significant expenditures, they are not unreasonable considering recent construction cost escalations, and that the estimated replacement cost of the entire system exceeds \$1.5 billion.

While the capital investment for proposed for 2010-2014 is significant, it will not be sufficient to provide adequate investment desired for all capital investments considered optimal or important at this time. The proposed level of investment for 2010-2014 will not provide adequate funding for inspection, preventative maintenance and rehabilitation of the existing infrastructure to prevent increases in engineering, maintenance and construction costs; expensive emergency repairs; and service disruptions to customers. While significant capital investments have been deferred to 2015 and beyond, to limit the total maximum debt to approximately \$175 million, the proposed 2010-2014 program still causes concern in relation to potential future rate increases and the amount of debt potentially required, particularly in relation to the existing maximum borrowing capacity of the City (\$200 million). These limitations and issues may be manageable over time, but they create risk issues for the City. The inability to provide the desired funding for inspection, preventative maintenance and rehabilitation of the existing infrastructure during 2010-2014, is coming primarily as a result of regulatory changes being implemented at provincial and federal levels without any corresponding commitment of funding from either level of government.

Capital requirements include an expansion to the Wastewater Treatment Plant to meet the Federal Government requirements under *The Canadian Environmental Protection Act* and *The Fisheries Act* as well as to comply with Saskatchewan Environment Regulations. Improvements are also required under the Provincial Water Quality Standards. Capital investments in the range of \$130 million are required over the next five years to upgrade and expand the City's wastewater treatment plant to meet more stringent provincial and federal regulations. While Utility rates were increased in 2008-10 to begin to address these pressures, the timing and magnitude of the increased revenue is insufficient to offset the timing and financial impact associated with such regulatory changes.

While an application has been made to the federal government to assist with funding the wastewater treatment plant expansion to meet new provincial and federal regulations, there is no certainty that such an application will be approved. Should no substantial funding be provided by other levels of government, the City will need to re-evaluate the proposed programs and budgets for 2011-14 for further possible deferrals in capital investments; increased utility rates; alternative funding/delivery mechanism; and/or potential reductions in level of service to Utility customers. To provide further flexibility to manage future anticipated debt levels within the Utility, Administration will also consult with the development community, assess the impacts, and provide recommendations to City Council regarding the need to proceed with, or defer the timing, of System Upgrades for Pressure Zone 2 specifically before construction is initiated.

In general terms, there may be an opportunity for Council to raise concerns at the political level relative to the Federal Government's willingness to properly fund its own standards.

Maintenance of the water, wastewater and drainage systems is a duty of the City in the interest of public health and safety. Ageing infrastructure, regulatory standards and Regina's environmental and geographic location all contribute to increasing costs, which result in a requirement to increase rates. The City has a duty to be responsible stewards of these essential utilities to promote the health, well being and economic opportunity of the community.

Respectfully submitted,



Glen B. Davies
City Manager

Introduction

2010 Budget Overview

The 2010 Water and Sewer Utility Operating and 2010 – 2014 Utility Capital Budgets reflect Regina's commitment to maintaining safe and secure Utility operations. Across North America, water and sewer rates are increasing as utilities face challenges relating to:

- replacement of aging infrastructure
- expansion of capacity
- improvements required to meet enhanced and/or more stringent regulations and standards.

The total capital investments proposed for 2010-2014 are approximately \$283 million. While the amount is significant, it will not be sufficient to provide adequate investment desired for all capital investments considered optimal or important at this time. The proposed level of investment for 2010-2014 will not provide adequate funding for inspection, preventative maintenance and rehabilitation of the existing infrastructure to prevent increases in engineering, maintenance and construction costs; expensive emergency repairs; and service disruptions to customers. While significant capital investments have been deferred to 2015 and beyond, the proposed 2010-2014 recommended program still causes concern in relation to potential future mill rate increases and the amount of debt potentially required, particularly in relation to the existing maximum borrowing capacity of the City. The inability to provide the desired funding for inspection, preventative maintenance and rehabilitation of the existing infrastructure during 2010-2014 is coming primarily as a result of regulatory changes being implemented at provincial and federal levels without any corresponding commitment of funding from either level of government.

Capital investments in the range of \$130 million are required over the next five years to upgrade and expand the City's wastewater treatment plant to meet more stringent provincial and federal regulations. While Utility rates were increased in 2008-10 to begin to address these pressures, the timing and magnitude of the increased revenue is insufficient to offset the timing and financial impact associated with such regulatory changes.

While an application has been made to the federal government to assist with funding the wastewater treatment plant expansion to meet new provincial and federal regulations, there is no certainty that such an application will be approved. Should no substantial funding be provided by other levels of government, the City will need to re-evaluate the proposed programs and budgets for 2011-2014 for further possible deferrals in capital investment, increased utility rate, alternative funding/delivery mechanism, and/or potential reductions in level of service to Utility customers.

In 2010, after three years of 9% increases, the price of a cubic metre of water is \$1.14, equivalent to two thousand 500 millilitre bottles, which would cost about \$4,000.

City Council has established its Vision for Regina:

**Imagine Regina 2020
Canada's most...
Vibrant,
Inclusive,
Attractive,
Sustainable community
Where people live in Harmony
And Thrive in opportunity.**

As part of the effort to achieve this vision, the Administration developed a corporate strategic plan for 2008 through 2012 and work continues on a performance management process to align with City Council's strategic direction.

The Corporate Strategic Plan - *Accelerating Excellence* - identified four strategic priorities:

- Managing Growth and Community Development
- Strengthening City Infrastructure and Managing Assets
- Achieving Operational Excellence
- Ensuring Organizational Capacity and Effectiveness

The Utility Budget development process included an assessment of new requests and existing funding, both operating and capital, in terms of their contribution to achieving these objectives.

Service Overview

The Water and Sewer Utility provides water, wastewater and drainage services primarily to customers in Regina. The services provided through the Utility include:

- **Water Supply, Pumping and Distribution**

The water system provides water for residential, institutional, commercial and industrial customers as well as water for fire protection. The system serves a population of approximately 200,000 including some customers outside the City limits. Service goals include:

- Providing water that meets or exceeds Provincial water quality standards and objectives.
- Providing water at adequate pressure and in sufficient quantity to satisfy the requirements for domestic and commercial use, irrigation and fire protection.
- Identifying and implementing improvements to the water system through long range planning, monitoring, improved operation, capital works and new technology.
- Participation in Communities of Tomorrow and National Research Council's Centre for Sustainable Infrastructure Research to develop new technologies and improve practices.

- **Wastewater Collection and Treatment**

The wastewater system collects wastewater from all residential, institutional, commercial and industrial customers in the City, and treats wastewater to meet Provincial and Federal environmental regulations and industry standards. Service goals include:

- Collecting domestic, commercial and industrial wastewater in the City and reliably delivering it to wastewater treatment facilities.
- Producing a treated wastewater effluent that is biologically and chemically safe for the environment and meets the requirements of the provincially issued operating permit.
- Ensuring pollutants removed from the wastewater are treated and disposed of in an environmentally responsible manner.

- **Drainage**

The drainage system controls water runoff resulting from rainfall and melting snow in and around the city. The system serves approximately 63,000 residential, institutional, commercial and industrial properties. Service goals include:

- Operating and maintaining the drainage system to control run-off water within the city to minimize inconvenience, property damage and danger to the public.
- Monitoring the potential for flood conditions in Wascana Creek and the storm channels and carrying out flood control measures as required.
- Provide environmental monitoring of storm water quality.

Regional Setting

Regina's location is a sensitive natural environment far from a major water source and is unique among most major Canadian cities. Regina's location impacts the standards and costs for water supply and wastewater treatment and disposal. The map on the next page provides an illustration of the regional setting.

Regina's water supply originates with snow melt and rainfall in the eastern Rocky Mountains that feed the tributaries of the South Saskatchewan River. The Gardiner and Qu'Appelle Dams impound the South Saskatchewan River to form Diefenbaker Lake from which water is released into the Qu'Appelle River. The Qu'Appelle River flows through Buffalo Pound Lake, the source of Regina and Moose Jaw's treated water supply. Buffalo Pound Lake is also the water source for large industrial users including the SaskFerco fertilizer plant and the Mosaic potash mine at Belle Plaine.

From Buffalo Pound Lake the Qu'Appelle River flows eastwards through the Fishing Lakes on its way to joining the Assiniboine in the east of the province. Saskatchewan Watershed Authority manages water releases from Lake Diefenbaker to support a variety of uses in the Qu'Appelle valley besides water supply. Releases maintain lake levels for recreation use and provide water for agricultural irrigation. The Watershed Authority also operates dams and control structures maintaining water levels when flows are low and controlling flooding when flows are high.

Wascana Creek is a seasonal stream that originates to the east of Regina and flows through the City to join the Qu'Appelle downstream of Lumsden. Regina's stormwater run-off and treated wastewater flow into Wascana Creek. For much of the year these sources are the only water that feeds Wascana Creek, and without these sources, the Creek would be dry.

The nature of the Qu'Appelle system is influenced by both its natural setting and its many uses. Abundant sunshine and naturally occurring nutrients result in a highly productive biological system typical of prairie water bodies. Human activities (agriculture and development) create their own demands and influence the system.

Regina is the centre of an economic region comprised of approximately 40 communities. Initiatives are underway to strengthen partnerships and to collaborate on mutual opportunities and interests. Regina's Utility systems provide some regional services and over time their role may increase.

Regina's water supply and wastewater treatment systems are adapted to provide treatment that is appropriate to its natural setting and to minimize the city's influence on the receiving environment.

Regina and Region

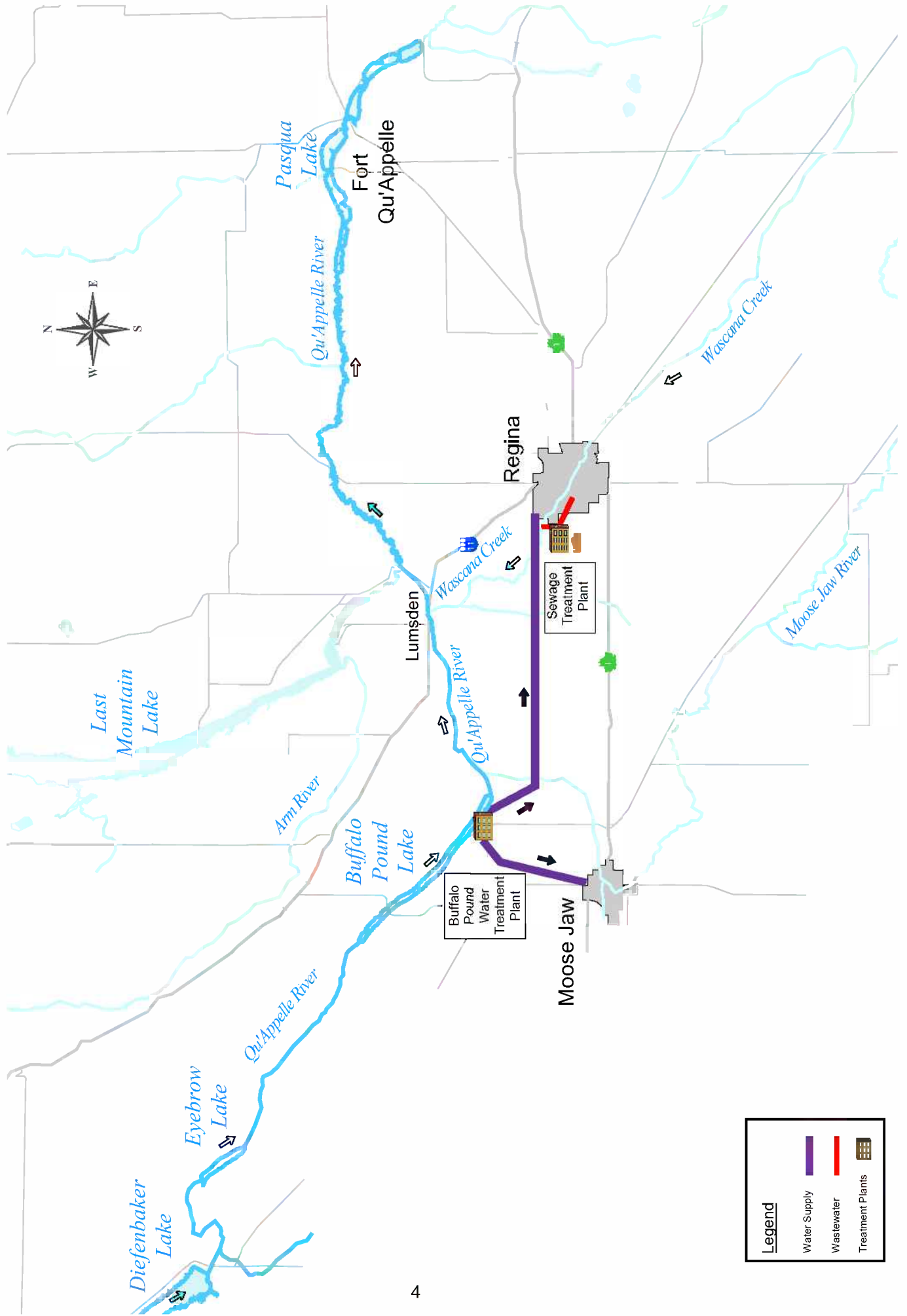

Regulatory Environment

Saskatchewan's Ministry of Environment regulates water supply and distribution, and wastewater collection, treatment and disposal. Permits for the construction and operation of water and wastewater systems require specific standards to protect human health and to minimize impacts on the natural environment. A system of routine testing, inspections and annual reports ensures compliance.

Saskatchewan Watershed Authority is responsible for management of Saskatchewan's surface water and ground water resources. The Authority regulates the allocation of water, establishes management plans for the province's river basins and is responsible for land drainage and wetland preservation and enhancement. In 2004, the Authority initiated a consultative process to develop a plan for the Upper Qu'Appelle. City Administration and the Buffalo Pound Water Administration Board were actively involved in the planning process, which was completed in 2009.

In 2002, the Province responded to public concerns, highlighted by the North Battleford cryptosporidium outbreak and subsequent inquiry, by passing new regulations pursuant to *The Environmental Management and Protection Act*. This Act with its regulations introduced a range of measures to ensure consistent water quality and appropriate environmental protection throughout Saskatchewan. The requirements include mandatory operator certification, routine facility inspections, testing and reporting.

The mandatory certification program requires water supply distribution, wastewater collection, and treatment operations to be under the direction of certified operators. The level of certification depends on the size and complexity of the system with Level One being the simplest and smallest systems and Level Four the largest and most complex. Regina's systems are designated as Level Four systems. The program provided a transition period to allow operators to achieve the required certification before July 15, 2005. Regina has certified operators and is organizationally designed to meet the certification requirements on an ongoing basis.

In 1999, the Federal Government enacted *The Canadian Environmental Protection Act*, (CEPA). This Act together with *The Fisheries Act* provides authority to regulate municipal wastewater effluents and control discharges to receiving waters. CEPA regulations require municipalities to address any substances deemed to be "toxic" under CEPA. At present only two substances, ammonia and chlorination by-products have been designated "toxic" but there is a list of other substances that could be so designated. Municipalities and Provincial regulators have been very concerned that Federal regulation with inflexible broadly-based national standards could replace the current site-specific regulatory regime. The Federal Government has issued a Guideline for addressing ammonia. It is expected the Federal Government will issue a regulation and timelines for addressing ammonia in wastewater discharges under *The Fisheries Act* in 2010.

The Canadian Council of Ministers of the Environment (CCME) has the Canada-wide Strategy for the Management of Municipal Wastewater Effluent. The CCME guidelines were completed in 2009. Implementation schedules will be completed on a case-by-case basis following adoption of the recommendations by the Federal Government in a regulation under *The Fisheries Act*. This CCME initiative, which has the support of the Federal Government, addresses the need to maintain a national approach to pollution prevention and environmental protection while recognizing local conditions and requirements. The CCME initiative may result in a more pragmatic approach to timing and implementing municipal wastewater effluent improvements than the initial CEPA Pollution Prevention Plan approach.

The environmental impacts to receiving waters are a key consideration for municipal wastewater effluent standards. City staff and Saskatchewan Ministry of Environment have discussed, and are in broad agreement, on the principle that treated effluent standards for the City's upgraded wastewater treatment plant should reflect and be determined by environmental effects in the Qu'Appelle system. To address this principle, the City continues to carry out significant monitoring program to document current conditions and help project future conditions in the Qu'Appelle system.

The City is involved in the Provincial Government's Duty to Consult process for the Wastewater Treatment Plant Expansion Project. This will continue through 2010.

Regina's practice has been to provide water and wastewater treatment that meets all regulatory requirements, anticipates potential higher standards and, where practical, meets the higher requirement. The investment required for regulatory compliance, such as the costs of training, certification, documentation and reporting will be higher than in the past. As well, there will be significantly higher capital investments required to meet the standards. The 2010 Utility Operating and 2010-2014 Utility Capital Budgets reflect these factors.

Financial Information

Customer Impact of Utility Rates

The 2008 – 2010 water, wastewater and drainage rates were approved by City Council in 2007. Examples of the impact of the 2010 rates are provided below.

Average Home Owner

The following chart illustrates the impact of the 2010 rates on a homeowner who uses 360 cubic metres of water per year. The water consumption is typical for a family of two adults and two children, in a home with two bathrooms, a dishwasher and washing machine, on a lot with typical landscaping for Regina. The cost increase resulting from the 2010 rates is about \$7.71 per month for the average homeowner.

2010 Rate Impact - Average Home Owner

	2009 (\$)	2010 (\$)	Dollar Change (\$)	Per Cent Change (%)
Water				
Annual Basic Charge	160.60	175.20	14.60	
Annual Volume Charge	378.00	410.40	32.40	
Total Annual Water	538.60	585.60	47.00	8.7
Wastewater				
Annual Basic Charge	124.10	135.05	10.95	
Annual Volume Charge	274.54	298.15	23.61	
Total Annual Wastewater	398.64	433.20	34.56	8.7
Annual Drainage Infrastructure Levy	105.85	116.80	10.95	10.3
Total Annual Utility Charges	1,043.09	1,135.60	92.51	8.9

Sample Commercial Customer

The following chart illustrates the impact of the 2010 rates on a commercial customer with a 40 mm meter that uses 3,000 cubic metres of water per year, with a property size in the range of 3,001 to 5,000 square metres. This water consumption would be typical for a strip-mall with a restaurant and a hair salon with a parking lot and minimal landscaping.

2010 Rate Impact - Sample Commercial Customer

	2009 (\$)	2010 (\$)	Dollar Change (\$)	Per Cent Change (%)
Water				
Annual Basic Charge	288.35	313.90	25.55	
Annual Volume Charge	3,150.00	3,420.00	270.00	
Total Annual Water	3,438.35	3,733.90	295.55	8.6
Wastewater				
Annual Basic Charge	222.65	244.55	21.90	
Annual Volume Charge	2,734.20	2,969.40	235.20	
Total Annual Wastewater	2,956.85	3,213.95	257.10	8.7
Annual Drainage Infrastructure Levy	423.40	467.00	43.60	10.3
Total Annual Utility Charges	6,818.60	7,414.85	596.25	8.7

Utility Operating Budget Summary

Details (\$000's)	2009 Budget	2009 Actual	2010 Budget	Change 2009 to 2010	
				Dollar Change(\$)	Per Cent Change(%)
Operating Revenue:					
Water	35,968.0	35,691.6	38,984.3	3,016.3	8.4
Wastewater	26,083.0	26,277.8	28,812.3	2,729.3	10.5
Drainage	7,842.9	7,908.1	8,784.0	941.1	12.0
Other	496.8	1,351.0	486.8	(10.0)	(2.0)
Total Operating Revenue	70,390.7	71,228.5	77,067.4	6,676.7	9.5
Operating Expenditures:					
Water, Wastewater & Drainage Operations and Construction	21,524.3	21,767.4	22,449.2	924.9	4.3
Wastewater Treatment	5,104.0	4,914.9	5,283.5	179.5	3.5
Engineering and Operations	6,391.2	5,549.3	6,512.9	121.7	1.9
Utility Administration	6,781.5	6,635.5	7,106.8	325.3	4.8
Transfer to General Operating ¹	5,436.3	5,436.3	5,873.9	437.6	8.0
Debt Costs	6,712.7	6,922.3	8,405.5	1,692.8	25.2
Total Operating Expenditures	51,950.0	51,225.7	55,631.8	3,681.8	7.1
Utility Operating Surplus	18,440.7	20,002.8	21,435.6	2,994.9	16.2
Distribution of Surplus:					
Transfer to General Utility Reserve ¹	18,440.7	20,002.8	21,435.6	2,994.9	16.2
Total Surplus	18,440.7	20,002.8	21,435.6	2,994.9	16.2

Note:

1. 2009 Budget figures are restated to reflect corrected transfer to General Operating Fund.

Utility Capital Program Summary

Details (\$000's)	2010	2011	2012	2013	2014	Total
Capital Expenditures (\$000's)						
Water Supply, Pumping & Distribution	15,524	14,294	14,107	9,944	9,924	63,793
Wastewater Collection & Treatment	34,065	29,990	57,790	55,890	7,490	185,225
Drainage	12,505	5,430	6,150	5,920	3,550	33,555
Total Expenditures	62,094	49,714	78,047	71,754	20,964	282,573
Capital Funding (\$000's)						
General Utility Reserve	41,872	17,195	8,906	16,193	18,323	102,489
Service Agreement Fees - Utility Debt	16,245	9,285	15,500	8,460	1,000	50,490
	-	22,550	52,000	45,460	-	120,010
Federal/Provincial Funding	3,799	-	-	-	-	3,799
Other External Contributions	178	684	1,641	1,641	1,641	5,785
Total Funding	62,094	49,714	78,047	71,754	20,964	282,573

Utility Operating Revenues

Revenue Details (\$000's)	2009 Budget	2009 Actual	2010 Budget	Change 2009 to 2010	
				Dollar Change (\$)	Percent Change %
Water Revenue					
Metered Water Charges	35,442.4	35,230.4	38,478.7	3,036.3	8.6
Unmetered Water Charges	208.6	122.5	208.6	-	0.0
Other Water Service Charges	317.0	338.7	297.0	(20.0)	-6.3
Subtotal	35,968.0	35,691.6	38,984.3	3,016.3	8.4
Wastewater Revenue					
Wastewater Charges	26,033.0	26,175.2	28,762.3	2,729.3	10.5
Wastewater Service Surcharge	50.0	102.6	50.0	-	0.0
Subtotal	26,083.0	26,277.8	28,812.3	2,729.3	10.5
Drainage Infrastructure Levy	7,842.9	7,908.1	8,784.0	941.1	12.0
Other Revenues:					
Service Fee Administration	-	-	-	-	-
Late Payment & Transfer Charges	240.0	151.6	230.0	(10.0)	-4.2
Claims Revenue	42.0	20.4	42.0	-	0.0
Other Revenues	214.8	1,179.0	214.8	-	0.0
Subtotal	496.8	1,351.0	486.8	(10.0)	-2.0
Total Utility Revenues	70,390.7	71,228.5	77,067.4	6,676.7	9.5

Use of 2010 Utility Revenue

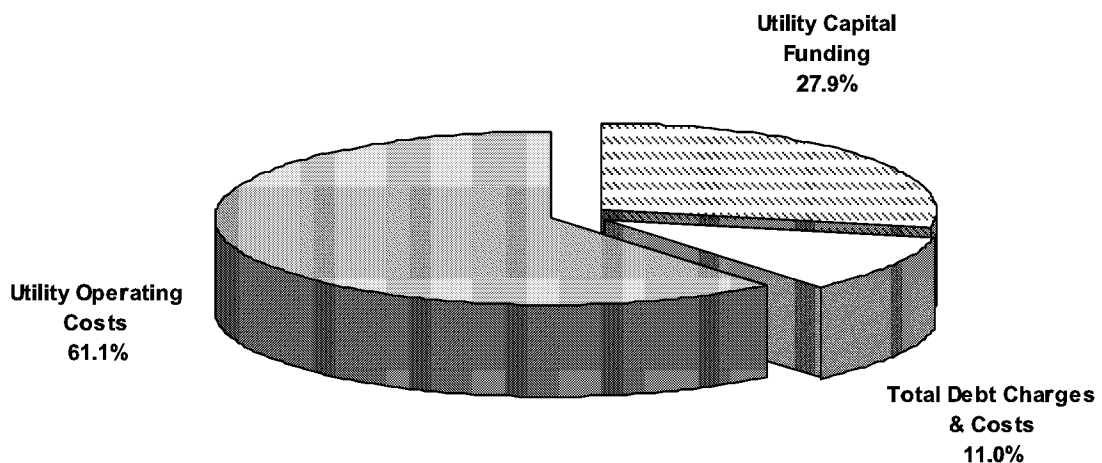

Utility Operating Expenditures

Expenditure Details (\$000's)	2009 Budget	2009 Actual	2010 Budget	Change 2009 to 2010	
				Dollar Change (\$)	Percent Change (%)
Water, Wastewater & Drainage Operations and Construction					
Water Operations	10,485.4	10,184.9	10,823.4	338.0	3.2
Water & Sewer Construction	7,884.6	8,411.4	8,020.1	135.5	1.7
Sewer & Drainage Operations	3,154.3	3,171.1	3,605.7	451.4	14.3
Subtotal	21,524.3	21,767.4	22,449.2	924.9	4.3
Wastewater Treatment	5,104.0	4,914.9	5,283.5	179.5	3.5
Engineering & Operations					
Strategic and Business Services	1,592.2	1,385.3	1,547.3	(44.9)	-2.8
Water, Wastewater Collection and Drainage Engineering	1,957.7	1,117.4	1,950.4	(7.3)	-0.4
Environmental Engineering	1,248.6	1,158.7	1,180.7	(67.9)	-5.4
Development Engineering	1,367.0	1,649.7	1,610.1	243.1	17.8
Facilities	225.7	238.2	224.4	(1.3)	-0.6
Subtotal	6,391.2	5,549.3	6,512.9	121.7	1.9
Utility Administration					
Customer Service, Billing & Collection	3,549.7	3,403.7	3,587.3	37.6	1.1
Transfer to General Operating ¹	5,436.3	5,436.3	5,873.9	437.6	8.0
Utility Administration Charge	3,231.8	3,231.8	3,519.5	287.7	8.9
Subtotal	12,217.8	12,071.8	12,980.7	762.9	6.2
Debt Costs	6,712.7	6,922.3	8,405.5	1,692.8	25.2
Total Utility Expenditures	51,950.0	51,225.7	55,631.8	3,681.8	7.1

Note:

- 2009 Budget figures are restated to reflect corrected transfer to General Operating Fund.

Staffing Summary

FTE's by Department	2009 ¹			2010			Change
	Permanent	Casual	Total	Permanent	Casual	Total	
Public Works	174.5	31.1	205.6	181.5	33.0	214.5	8.9
Planning & Development	13.8	1.6	15.4	16.8	1.6	18.4	3.0
Corporate Services	24.5	2.0	26.5	24.5	2.0	26.5	-
Office of the City Manager	9.8	0.5	10.3	9.8	0.4	10.2	- 0.1
Total	222.6	35.2	257.8	232.6	37.0	269.6	11.8

Note:

- The 2009 staffing summary has been restated to correctly reflect allocated staffing.
- Three positions in Planning & Development were approved in the 2008 budget, but were not added to the 2009 budget. Those positions have been reinstated in the 2010 FTE figure.

Analysis of Operating Budget Change from 2009 to 2010

Details of Operating Budget Changes <i>(continued on next page)</i>	(\$000's)
2009 Operating Budget Before Transfers and Debt	51,950.0
1. Salaries and Benefits - Includes cost changes resulting from in-range progression increases, classification reviews, general employer benefit costs (EI, CPP, WCB, etc. which increase proportionate with salaries), the City's portion of increases in employee pension contributions and allowance for negotiated salary increase. (Base)	319.5
2. 2009 One Time Items - This represents one time items contained in the 2009 budget and includes Wastewater Trunk System (-\$400,000), Collections Field Services Resources (-\$45,000), In-pipe Technologies Pilot Study (-\$400,000), as well as several requests that were not completed in 2009 along with a number of other smaller items. (One-Time)	(1,540.1)
3. Allocations - Adjustment to allocations between the General Fund and the Utility, including Customer Service, Strategic and Business Services (Public Works), Development Engineering, and Environmental Engineering. (Base)	205.0
4. Power and Energy Costs - Increased energy costs for various operations including Wastewater Treatment Plant, Water Pumping, Wells, and Forcemain Operations. (Base)	149.9
5. Curb Box Replacements: Increased cost of materials and equipment to maintain current level of service for replacing curb boxes. (Base)	89.7
6. Utility Billing Postage - Increased postage rates along with increased number of billing accounts has resulted in increased costs to mail bills. (Base)	32.7
7. Deposit Interest - Deposits have been eliminated as part of the new delinquency processes, resulting in the elimination of deposit interest expense. (Base)	(30.1)
8. Landfill rates - The Water and Sewer Construction operation generates waste that must be disposed of at the City's landfill. This base change addresses the increased rates for both 2009 and 2010. (Base)	40.0
9. Liquid Alum - Increased cost of liquid alum (aluminium sulphate), which is utilized on a continuous basis in the treatment of wastewater. (Base)	31.0
10. Purchase of Water - Increase in cost of water from Buffalo Pound Water Treatment Plant. (Base)	300.0
11. Pipes and Tubing - To cover rising costs associated with the supply and shipping of water & sewer pipe and tubing. (Base)	125.0
12. Chemical Costs - Increase in cost of chemicals for operation of forcemains. (Base)	20.0
13. Operation of Wells - Because of reduction in use of the City's wells, the costs associated with the operation, including chlorine and equipment, have been reduced. (Base)	(17.2)
14. Testing and Laboratory Services - Increase in cost of chemicals and laboratory equipment for the Wastewater Treatment Plant. (Base)	22.0
15. Engineering Assistant for Cross Connection Control (CCC) Program - This position will assist the Coordinator with reviewing the installation, inspection, and testing of backflow prevention devices. Funding is also provided for software required to replace the current system. (increase 1.0 Permanent FTE) (Addition)	70.0
16. Utility Billing Collection Support - Changes to the delinquency process for Utility Billing have resulted in reduced bad debt expense. In order to support this change, additional casual staff support is required for peak periods. (Increase 0.5 Casual FTE) (Addition)	25.4
17. Clean out Installation - Installing cleanouts at the property line to better service the sewer lateral. (Increase 1.0 Permanent FTE) (Addition)	44.0

Details of Operating Budget Changes <i>(continued from previous page)</i>		(\$000's)
18	Utility Infrastructure Strategy - In 2009, a consultant was engaged to provide strategic leadership to develop an infrastructure management strategy for the Utility. Includes \$65,000 for consulting services to complete phase 2 of this project as well as \$90,000 for a new position to provide ongoing management. (Increase 1.0 Permanent FTE) (One-Time/Addition)	155.0
19	Storm Channel Maintenance - Additional resources are required for an improved level of maintenance for storm channels. (Increase 0.5 Casual FTE) (Addition)	50.0
20.	Siphon Inspection - The siphons in the City Wastewater system need to be inspected from time to time to determine condition, necessary repairs and/or cleaning. A contractor will be hired to inspect all siphons during 2010 and provide recommendations. (Addition)	75.0
21.	Sewer Main Maintenance - Additional staffing resources are required to increase the quantity of work and related frequency of cleaning sewer mains. (Increase 1.0 Permanent FTE) (Addition)	100.0
22.	Raising/Lowering Manholes - Increased resources are required to adjust top elevations of sewer and drainage manholes to match pavement levels to improve the drivability of roads. (Increase 1.0 Permanent FTE) (Addition)	100.0
23.	Lift Station Maintenance - Increased resources to improve maintenance and reliability of thirty automated sewage and storm water lift stations. Funding includes \$110,000 for additional staffing and related costs and \$45,000 for one time cost to refurbish generators. (Increase 2.0 Permanent FTE) (Addition/One-Time)	155.0
24.	Legal Claims - To resolve outstanding legal proceedings. (One-Time)	100.0
25.	Environmental Monitoring - Provision for environmental studies on Wascana and Qu'Appelle River Lake Systems to assess impacts of urban treated wastewater as required by provincial and federal requirements. (One-Time)	100.0
26.	Utility Business Plan - Funding for consulting services to initiate development of a Utility Business Plan, to align with City Councils vision and the City's Strategic Plan. The work will also include a Rate Review to establish rates for 2011-2013. (One-Time)	75.0
27.	Water System Testing - Funding required for increased testing of the water distribution system in response to Health Canada recommendations. Also provides for equipment for increased testing conducted on projects. (One-Time)	15.0
28.	Preventative Maintenance (PM) Program - One time funding for the establishment of a (PM) program for Water, Wastewater and Storm Drainage operations to reduce long term costs and improve reliability. (One-Time)	75.0
29.	Wastewater Assessment - Funding to complete wastewater trunk system assessment initiated in 2008. This assessment will provide a model that incorporates previous studies with new information from areas previously not assessed. (One-Time)	300.0
30.	Administrative Charge - Increase in the administrative charge as per the policy. The charge is 5% of the prior year's budgeted revenue. (Base)	287.7
31.	Debt Costs - This represents the change in total interest and principle payments for the Utility in 2010. (Base)	1,692.8
32.	Transfer in Lieu of Taxes - Increase in Transfer to General Operating Fund in Lieu of Taxes. (Base)	437.6
33.	Other miscellaneous costs include funding for benchmarking, changes to water efficiency programs, membership in the Wascana and Upper Qu'Appelle Watersheds Association Taking Responsibility, Inc. (WUQWATR), and changes to allocated IT costs. (Base)	76.9
2010 Budget		55,631.8

Note:

Base request funding – represents an increase in cost necessary to maintain current investment levels.

Addition request funding – represents expenditures that would be ongoing past the current budget year.

One-Time request funding – represents one-time expenditures for the current budget year

Utility Rates and Rate Policies

Section 22.3 of *The Cities Regulations* requires Council to adopt a rate policy that sets out the rates or fees to be charged to consumers for the use of water. The policy must include the method used to determine those rates or fees. In establishing Utility rates, the following policies have been adopted in the past by City Council:

1. Utility rates are to be established such that they are sufficient, based on long term projections, to fully fund Utility operating costs, interest cost and debt repayments, capital requirements, and transfer policies, taking into account the operating and infrastructure requirements of the Utility required to meet the service goals of the Utility, as determined by City Council or prescribed by legislation. The objectives for the Utility's rate structure are:
 - **Financial Self Sufficiency** – Utility rates must generate revenue adequate to meet all operating and capital costs of the Utility in both the short and the long term.
 - **Conservation** – Utility rates should encourage customers to use water responsibly.
 - **Reduction of Peak Demand** – The Utility rates should encourage water conservation during summer months, reducing the need for infrastructure investment and higher rates.
 - **Equity** – The Utility rates should result in a charge to customers according to the cost of services utilized.
2. The rate structure for water and wastewater will include a base fee that varies according to the size of the water meter. The variation in the base rate by meter size will be based on the schedule recommended by the American Water Works Association (AWWA). The ratios for the base rate based on meter size are shown in the following table.

Water and Wastewater Base Fee Ratios

Meter Size	AWWA Standard Ratio
15 mm	1.0
18 mm	1.0
25 mm	1.4
40 mm	1.8
50 mm	2.9
75 mm	11
100 mm	14
150 mm	21
200 mm	29

3. The rate structure for water and wastewater will include a uniform rate for each cubic metre of water consumed and each cubic metre of deemed wastewater flow. For water, the uniform rate is applied to all consumption. For wastewater, the deemed volume is a percentage of the water consumption. The percentages are:
 - For residential customers, the wastewater volume is 82% of the water consumption;
 - For multiple unit residential properties, the percentage is 95% of the water consumption; and,
 - For institutional, commercial and industrial properties, the percentage is 98% of the water consumption.

4. The rate structure for the storm drainage infrastructure levy will be based on the size of the property, with larger properties paying a higher levy. The ratios approved by City Council in 2001 (CR01-189) are shown in the following table. The drainage levy applies irrespective of whether the property is connected to the water or wastewater systems.

Drainage Infrastructure Rate Ratios

<u>Area of Property</u>	<u>Rate Ratio</u>
0 to 1,000 m ²	1.0
1,001 to 3,000 m ²	2.0
3,001 to 5,000 m ²	4.0
5,001 to 7,000 m ²	6.0
7,001 to 9,000 m ²	8.0
9,001 to 11,000 m ²	10.0
11,001 to 13,000 m ²	12.0
13,001 to 15,000 m ²	14.0
15,001 to 17,000 m ²	16.0
17,001 to 19,000 m ²	18.0
19,001 to 21,000 m ²	20.0
21,001 to 23,000 m ²	22.0
23,001 to 25,000 m ²	24.0
25,001 to 27,000 m ²	26.0
27,001 to 29,000 m ²	28.0
29,001 to 31,000 m ²	30.0
Over 31,000 m ²	32.0

5. **In the setting of rates, the Utility must at minimum present a balanced budget**, with any surplus intended for the following purposes:

- **Transfer to the General Utility Reserve** –The purpose of the reserve is to provide a source of financing for capital projects. The balance of the Utility’s surplus, after other transfers, is transferred to the General Utility Reserve. For 2010, the transfer is budgeted at **\$21.4 million**. Through the use of the Utility Model, an overall requirement for capital funding is established. Utility rates are set in order to provide sufficient surpluses to cover the capital costs over the next twenty years.

In the event that the Utility incurs an operating deficit in a given year, the deficit would also be funded from the reserve.

6. **The Utility Operating Expenses also include a transfer to the City’s General Operating Fund in lieu of taxes.** Any organization or Utility operating in a municipality would be required to pay the municipality either property taxes or an ‘Access Fee’ for the rights to use or access civic assets in the delivery of service. Policies on these types of fees vary from city to city. Calgary’s Utility pays 10% of revenue plus a 10% return on equity. The City of Saskatoon’s Utility pays a franchise fee based on 10% of revenue. Winnipeg’s is also 10%, with dividends paid. Moose Jaw’s rate is 5% of revenue. Regina’s transfer is the total of the following amounts:

- 7.5% of the previous years budgeted revenues for billed water consumption, wastewater charges and drainage infrastructure levy; and,
- The amount of \$675,000, estimated to be 3/7^{ths} of the GST rebate received by the Utility. This amount is the additional rebate provided by the Federal Government starting in 2004.

For 2010, these amounts total \$5,873,900.

City Council's practice has been to establish Utility rates every three years, with a three-year schedule of rates adopted. In 2007, rates were set for the 2008 – 2010 period.

The approved Utility rates for 2008 through 2010 are shown in the following tables. Rates are billed monthly and are based on a daily fixed charge.

Water Rates

	Current Rate Schedule		
	2008 (\$)	2009 (\$)	2010 (\$)
Daily Base Fee:			
15 mm/18 mm water meter	0.40	0.44	0.48
25 mm water meter	0.56	0.62	0.67
40 mm water meter	0.72	0.79	0.86
50 mm water meter	1.16	1.28	1.39
75 mm water meter	4.40	4.84	5.28
100 mm water meter	5.60	6.16	6.72
150 mm water meter	8.40	9.24	10.08
200 mm water meter	11.60	12.76	13.92
Volume Charge:			
Charge per m ³	0.96	1.05	1.14

Wastewater Rates

	Current Rate Schedule		
	2008 (\$)	2009 (\$)	2010 (\$)
Daily Base Fee:			
15 mm/18 mm water meter	0.31	0.34	0.37
25 mm water meter	0.43	0.48	0.52
40 mm water meter	0.56	0.61	0.67
50 mm water meter	0.90	0.99	1.07
75 mm water meter	3.41	3.74	4.07
100 mm water meter	4.34	4.76	5.18
150 mm water meter	6.51	7.14	7.77
200 mm water meter	8.99	9.86	10.73
Volume Charge:			
Charge per m ³	0.85	0.93	1.01

Storm Drainage Rates

Daily Base Fee	Current Rate Schedule		
	2008 (\$)	2009 (\$)	2010 (\$)
0 to 1,000 m ²	0.27	0.29	0.32
1,001 to 3,000 m ²	0.54	0.58	0.64
3,001 to 5,000 m ²	1.08	1.16	1.28
5,001 to 7,000 m ²	1.62	1.74	1.92
7,001 to 9,000 m ²	2.16	2.32	2.56
9,001 to 11,000 m ²	2.70	2.90	3.20
11,001 to 13,000 m ²	3.24	3.48	3.84
13,001 to 15,000 m ²	3.78	4.06	4.48
15,001 to 17,000 m ²	4.32	4.64	5.12
17,001 to 19,000 m ²	4.86	5.22	5.76
19,001 to 21,000 m ²	5.40	5.80	6.40
21,001 to 23,000 m ²	5.94	6.38	7.04
23,001 to 25,000 m ²	6.48	6.96	7.68
25,001 to 27,000 m ²	7.02	7.54	8.32
27,001 to 29,000 m ²	7.56	8.12	8.96
29,001 to 31,000 m ²	8.10	8.70	9.60
Over 31,000 m ²	8.64	9.28	10.24

Utility Model

The purpose of the model is to project future operating revenues and expenditures along with capital requirements and capital funding. The major decisions in generating the projections for the Utility model are:

- **Utility Rates** – While the objective is to minimize the need for rate increases, a parallel objective is to ensure required rate increases are gradual, rather than having large increases when major capital investments are required.
- **Capital Investments** – There are service goals for each component of the Utility that determine the long term capital requirements. There is some flexibility in planning for capital investments. The Utility Model can be used to evaluate the financial implications of alternate schedules for capital investments.
- **Capital Funding** – Historically, capital funding has been provided through the issuing of debt or the use of internal reserves. The Utility Model can be used to evaluate the implications of the use of debt.

The Utility Model is based on the following assumptions:

- **Water Consumption** – The model uses an annual billable water consumption figure of almost 23.5 million cubic metres. The model is based on the current trend for water consumption and the assumption that total consumption will not change significantly in the future.
- **Operating Costs** – The model uses the 2010 operating budget and applies an inflation rate of 3% per year to forecast operating costs for the next 20 years. The cost of water supplied by the Buffalo Pound Water Treatment Plant is projected to increase at a rate of 5% per year. Actual costs will differ from the projected costs over time, but the assumptions are considered reasonable for the purpose of the model.

- **Utility Rates** – The Utility rates approved for 2008 to 2010 are used in the model. For the period 2008 through 2010, rate increases have been 9% per year. Future rate increases are dependent primarily on the projected level of capital investment. Changes in future capital requirements will result in a change in future rate requirements.
- **Capital Investments** – The model accommodates the capital investments in the 2010 – 2014 Utility Capital Program, along with future capital requirements based on a 20-year capital investment plan. The current version of the Utility Model has projected capital costs (based on current dollars) of over \$670 million from 2015 to 2029.
- **Capital Funding** – The model includes projections for capital funding from the General Utility Reserve and Utility Servicing Agreement Fees. Capital funding beyond that available from the reserve or Servicing Agreement Fees must be provided through external financing. 2009 debt in the amount of \$42.4M originally taken to finance the Global Transportation Hub has been reassigned to the Utility. This debt is not considered new debt for 2010, but must be considered as part of the total debt requirements for the Utility. In addition to this debt, the 2010 to 2014 Utility Capital program will require a further \$120 million in debt financing: \$22.6 million in 2011, \$52 million in 2012, and \$45.5 million in 2013. In 2014, the GTH debt will mature and the new debt of \$30 million will be required to replace it. Additional debt financing is projected to be required beyond 2014.

Utility Customers

The Utility provides services to a population of approximately 200,000 including service to some customers and communities outside of the City limits. The following tables provide information on the number and categories of Utility customers.

Water and Sewer Utility Customers

	<u>Water Customers</u>	<u>Wastewater Customers</u>	<u>Drainage Customers</u>
Residential	58,442	58,431	57,342
Multi-Unit Residential	833	833	814
Commercial	3,168	3,068	3,188
Irrigation	308	37	-
Total	<u>62,751</u>	<u>62,369</u>	<u>61,344</u>
Within City Limits	62,609	62,331	61,344
Outside City Limits	142	38	-
Total	<u>62,751</u>	<u>62,369</u>	<u>61,344</u>

Water Customers

Water	Multi-Unit			Irrigation	Total
	Residential	Residential	Commercial		
15 mm - 5/8"	55,641	26	1,210	11	56,888
18 mm - 3/4"	2,655	230	1,083	28	3,996
25 mm - 1"	132	359	399	90	980
40 mm - 1.5"	14	108	154	57	333
50 mm - 2"	-	54	184	111	349
75 mm - 3"	-	56	116	8	180
100 mm - 4"	-	-	15	3	18
150 mm - 6"	-	-	5	-	5
200 mm - 8"	-	-	2	-	2
Total	58,442	833	3,168	308	62,751

Wastewater Customers

Wastewater	Multi-Unit			Irrigation	Total
	Residential	Residential	Commercial		
15 mm - 5/8"	55,641	26	1,206	7	56,880
18 mm - 3/4"	2,645	230	1,057	3	3,935
25 mm - 1"	132	359	381	12	884
40 mm - 1.5"	13	108	146	6	273
50 mm - 2"	-	54	150	7	211
75 mm - 3"	-	56	110	2	168
100 mm - 4"	-	-	11	-	11
150 mm - 6"	-	-	5	-	5
200 mm - 8"	-	-	2	-	2
Total	58,431	833	3,068	37	62,369

Drainage Customers

Drainage	Multi-Unit		Commercial	
	Residential	Residential		
0 to 1,000 m ²	57,339	383	1,352	59,074
1,001 to 3,000 m ²	1	310	803	1,114
3,001 to 5,000 m ²	-	45	320	365
5,001 to 7,000 m ²	1	29	162	192
7,001 to 9,000 m ²	-	11	109	120
9,001 to 11,000 m ²	-	10	73	83
11,001 to 13,000 m ²	1	9	54	64
13,001 to 15,000 m ²	-	4	54	58
15,001 to 17,000 m ²	-	1	43	44
17,001 to 19,000 m ²	-	3	25	28
19,001 to 21,000 m ²	-	4	33	37
21,001 to 23,000 m ²	-	2	17	19
23,001 to 25,000 m ²	-	1	13	14
25,001 to 27,000 m ²	-	1	9	10
27,001 to 29,000 m ²	-	-	11	11
29,001 to 31,000 m ²	-	-	6	6
Over 31,000 m ²	-	1	104	105
Total Properties	57,342	814	3,188	61,344

Utility Rate History and Comparisons

The following tables detail the history of Utility rates since 1992, and the annual cost and annual cost increase for a sample residential customer with 360 cubic metres of water consumption a year.

Year	Annual Consumption			Cost for Sample Customer	
	in Fixed Charge (Cubic Metres)	Fixed Annual Charge (\$)	Volume Charge (\$/Cubic Metre)	Annual Charge for 360 cubic metres (\$)	Per Cent Increase (%)
1992	169.8	98.40	0.593	211.20	5.2
1993	169.8	106.20	0.643	228.48	8.2
1994	169.8	115.20	0.693	247.02	8.1
1995	169.8	121.20	0.728	259.68	5.1
1996	150.0	125.10	0.740	280.50	8.0
1997	132.0	131.40	0.750	302.40	7.8
1998	114.0	138.00	0.750	322.50	6.6
1999	90.0	138.00	0.750	336.00	4.2
2000	78.0	138.00	0.750	349.50	4.0
2001	60.0	138.00	0.750	363.00	3.9
2002	none	105.00	0.770	382.20	5.3
2003	none	109.50	0.790	393.90	3.1
2004	none	117.00	0.810	408.60	3.7
2005	none	123.00	0.830	421.80	3.2
2006	none	129.00	0.850	435.00	3.1
2007	none	135.05	0.880	451.85	3.9
2008	none	146.00	0.960	491.60	8.8
2009	none	160.60	1.050	538.60	9.6
2010	none	175.20	1.140	585.60	8.7

Wastewater Rate History

Year	Annual Consumption			Cost for Sample Customer	
	in Fixed Charge (Cubic Metres)	Fixed Annual Charge (\$)	Volume Charge (\$/Cubic Metre)	Annual Charge for 360 cubic metres (\$)	Per Cent Increase (%)
1992	28.3	94.80	0.601	169.44	13.6
1993	28.3	102.60	0.650	183.36	8.2
1994	28.3	111.00	0.700	197.94	8.0
1995	28.3	114.60	0.721	204.18	3.2
1996	25.0	105.00	0.690	204.36	0.1
1997	22.0	105.90	0.660	212.82	4.1
1998	19.0	106.50	0.630	219.90	3.3
1999	16.0	106.50	0.630	231.24	5.2
2000	13.0	106.50	0.630	242.58	4.9
2001	10.0	106.50	0.630	253.92	4.7
2002	none	76.50	0.650	268.38	5.7
2003	none	81.00	0.670	278.78	3.9
2004	none	87.00	0.690	290.69	4.3
2005	none	93.00	0.720	305.54	5.1
2006	none	99.00	0.750	320.40	4.9
2007	none	102.20	0.780	332.46	3.8
2008	none	116.80	0.850	364.07	9.5
2009	none	124.10	0.930	398.64	9.5
2010	none	135.05	1.010	433.20	8.7

Drainage Infrastructure Levy Rate History

Year	Property Category	Annual Levy (\$)	Percentage Increase (%)
1992	All	24.00	n/a
1993	All	30.00	25.0
1994	All	36.00	20.0
1995	All	42.00	16.7
1996	1,000 square metres or less	42.00	-
1997	1,000 square metres or less	43.20	2.9
1998	1,000 square metres or less	44.40	2.8
1999	1,000 square metres or less	45.60	2.7
2000	1,000 square metres or less	46.80	2.6
2001	1,000 square metres or less	48.00	2.6
2002	1,000 square metres or less	49.20	2.5
2003	1,000 square metres or less	60.00	22.0
2004	1,000 square metres or less	72.00	20.0
2005	1,000 square metres or less	78.00	8.3
2006	1,000 square metres or less	84.00	7.7
2007	1,000 square metres or less	91.25	8.6
2008	1,000 square metres or less	98.55	8.0
2009	1,000 square metres or less	105.85	7.4
2010	1,000 square metres or less	116.80	10.3

Rate Comparison - Sample Residential Customer

The following chart compares the 2010 rates for Regina and other cities for a sample residential customer. The sample customer is a home owner who uses 360 cubic metres of water per year. The water consumption is typical for a family of two adults and two children, in a home with two bathrooms, a dishwasher and washing machine, on a lot with typical landscaping for Regina.

Sample Residential Customer - 2010 Rates

<u>Utility Bill Details</u>	<u>Regina</u>	<u>Calgary</u>	<u>Edmonton</u>	<u>Saskatoon</u>	<u>Winnipeg</u>
Water					
Annual Basic Charge	\$ 175.20	\$ 146.04	\$ 65.04	\$ 82.68	\$ 55.00
Annual Volume Charge	410.40	477.65	553.03	305.12	464.40
Total Annual Water	<u>585.60</u>	<u>623.69</u>	<u>618.07</u>	<u>387.80</u>	<u>519.40</u>
Wastewater					
Annual Basic Charge	135.05	127.56	73.08	82.68	-
Annual Volume Charge	298.15	250.31	418.61	147.47	687.60
Total Annual Wastewater	<u>433.20</u>	<u>377.87</u>	<u>491.69</u>	<u>230.15</u>	<u>687.60</u>
Annual Drainage Infrastructure Levy	116.80	91.92	120.73	108.65	-
Total Annual Utility Charges	<u>\$ 1,135.60</u>	<u>\$ 1,093.48</u>	<u>\$ 1,230.49</u>	<u>\$ 726.60</u>	<u>\$ 1,207.00</u>

Rate Comparison - Sample Commercial Customer

The following chart compares the 2010 rates for Regina and other cities for a sample commercial customer. The commercial customer has a 40 mm meter, uses 3,000 cubic metres of water per year, with a property size in the range of 3,001 to 5,000 square metres. This water consumption would be typical for a strip-mall with a restaurant and a hair salon with a parking lot and minimal landscaping.

Sample Commercial Customer - 2010 Rates

<u>Utility Bill Details</u>	<u>Regina</u>	<u>Calgary</u>	<u>Edmonton</u>	<u>Saskatoon</u>	<u>Winnipeg</u>
Water:					
Annual Basic Charge	\$ 313.90	\$ 393.96	\$ 198.00	\$ 1,297.44	\$ 124.10
Annual Volume Charge	3,420.00	2,992.20	2,829.66	1,974.87	3,544.96
Total Annual Water	<u>3,733.90</u>	<u>3,386.16</u>	<u>3,027.66</u>	<u>3,272.31</u>	<u>3,669.06</u>
Wastewater:					
Annual Basic Charge	244.55	127.56	73.08	1,297.44	-
Annual Volume Charge	2,969.40	1,981.50	3,488.40	1,480.09	5,730.00
Total Annual Wastewater	<u>3,213.95</u>	<u>2,109.06</u>	<u>3,561.48</u>	<u>2,777.53</u>	<u>5,730.00</u>
Drainage Infrastructure Levy	467.00	91.92	1,091.45	816.62	-
Total Annual Utility Charges	<u>\$ 7,414.85</u>	<u>\$ 5,587.14</u>	<u>\$ 7,680.59</u>	<u>\$ 6,866.46</u>	<u>\$ 9,399.06</u>

Water

Initiatives for 2010

- Undertake consultant selection and proceed with pre-design work for the Buffalo Pound Water Treatment Plant process upgrades.
- Implement a new process for installing water meters in new buildings.
- Purchase equipment and implement a comprehensive program to improve the reliability of the infrastructure system (valves).
- Replace existing electronic control system (SCADA) for monitoring and operating the water supply system.
- Complete design and construction of Albert Street Reservoir Roof Repair. Repair of the roof structure will extend the service life of the reservoir and prevent failure of the reservoir structure.
- Begin detailed design and construction of system upgrades for Second Pressure Zone. Initiate construction of some of the upgrades in 2010 with remainder of work planned for completion in 2011.
- Complete pipe inspection pilots for Asbestos-Cement (AC) and large diameter cast iron watermains to assess condition and evaluate inspection technology.
- Complete pilot to evaluate watermain relining technologies and feasibility for use as a more cost effective alternative to excavation and replacement.
- Complete design and construction of a Bulk Water Loading Station to relieve operation and safety issues associated with current location.
- Replace watermain fire hydrants, valves and service lines in conjunction with roadway improvements.
- Review water distribution system capacity to evaluate regional supply viability.
- Undertake Southeast Sector Serviceability Review for long term water supply and distribution to support City growth.

Status of 2009 Initiatives

- Accuracy testing and repair of intermediate sized water meters was started. Accuracy testing will continue in 2010 and results will be evaluated.
- Completed a review of the current Water Bylaw and made required interim revisions. Further Bylaw revisions will be completed in 2010.
- Completed selection and tender of valves for Buffalo Pound Supply Line swab retrieval structure. Completed conceptual design of swab retrieval for construction in 2010.
- Removed check valve at the Keystown Booster Station to accomplish the following: facilitate easier cleaning of the 900 mm diameter Buffalo Pound Supply Line, eliminate the need for future maintenance of the valve, and facilitate future decommissioning of the Keystown Booster Station.

- Completed Albert Street Reservoir Inspection Report and engaged consultant for engineering design.
- Completed installation of equipment for a field study in collaboration with the National Research Council's Centre for Sustainable Infrastructure Research in Regina and the University of Regina to examine the behaviour of expansive soils and potential effects on AC watermains.
- Developed a preliminary 5 year work plan for potential water system inspection, maintenance and upgrade programs.
- Replaced watermains, fire hydrants, valves and service lines in conjunction with roadways improvements.
- Completed conceptual and pre-design stages for options to improve pressure and flow to existing areas and future growth areas on the north side of the City.
- Provisions for water supply to the Global Transportation Hub (GTH) were initiated in 2009. Completion of the water distribution system for the first phase of the GTH is expected in 2010.

Water System Overview

The water supply, pumping and distribution system provides water for residential and commercial use and fire protection. The system serves a population of approximately 200,000 including all residents and businesses in the city limits and a number of customers outside the city. Service goals include:

- Providing water that meets or exceeds Provincial water quality standards and objectives.
- Providing water at adequate pressure and in sufficient quantity to satisfy the requirements for domestic and commercial use, irrigation and fire protection.
- Identifying and implementing improvements to the water system through long range planning, monitoring, improved operation, capital works and new technology.
- Participation in Communities of Tomorrow and National Research Council's Centre for Sustainable Infrastructure Research to develop new technologies and improve practices.

Components of the water system shown in the map on page 25 include:

- **Buffalo Pound Lake and Wells** – All of the annual water needs are provided from Buffalo Pound Lake. There are wells available for backup purposes. The well water is chlorinated, but does not require further treatment to meet current health standards.
- **Buffalo Pound Water Treatment Plant** – Water from Buffalo Pound Lake is drawn and pumped three kilometres to the Buffalo Pound Water Treatment Plant, a facility owned jointly with the City of Moose Jaw. At the plant, the water is mixed with coagulants that cause algae, bacteria and other impurities to clump together so that they settle out of the water. The water is then filtered and chlorinated. During warmer weather, the water is passed through granular activated carbon to improve the taste and odour.
- **Supply Pipelines** – From the Buffalo Pound Water Treatment Plant, the water is pumped through a 56 km pipeline to the City's water distribution system. The pipeline has been twinned to provide increased capacity and reliability of the water supply. A number of other supply pipelines transport water from wells to reservoirs.

- **Reservoirs** – Five storage reservoirs are used to store water to meet peak demands and ensure that there is an adequate supply of water available for firefighting and high usage periods. The reservoirs have a combined usable storage capacity equal to about one and one-half days of average water use.
- **Pumping Stations** – There are three pumping stations (North, Farrell and Ross) that are used to pump water from reservoirs into the distribution system as necessary.
- **Distribution System** – The distribution system consists of over 1,070 kilometres of pipelines ranging in size from large 1,067 mm diameter trunk mains to 100 mm distribution pipes. The pipelines are made of various materials – AC, coated steel and polyvinyl chloride (PVC). The distribution system also includes over 6,000 valves that allow the water to be turned off to facilitate repairs and maintenance.
- **Service Connections** – Distribution pipes are connected to a customer's water line through a service connection.
- **Water Meters** – Water meters measure water consumption. A water meter replacement program was completed in 2004. The project included the installation of automated meter reading (AMR) equipment to transmit meter readings to a mobile data collection unit.

WATER SYSTEM

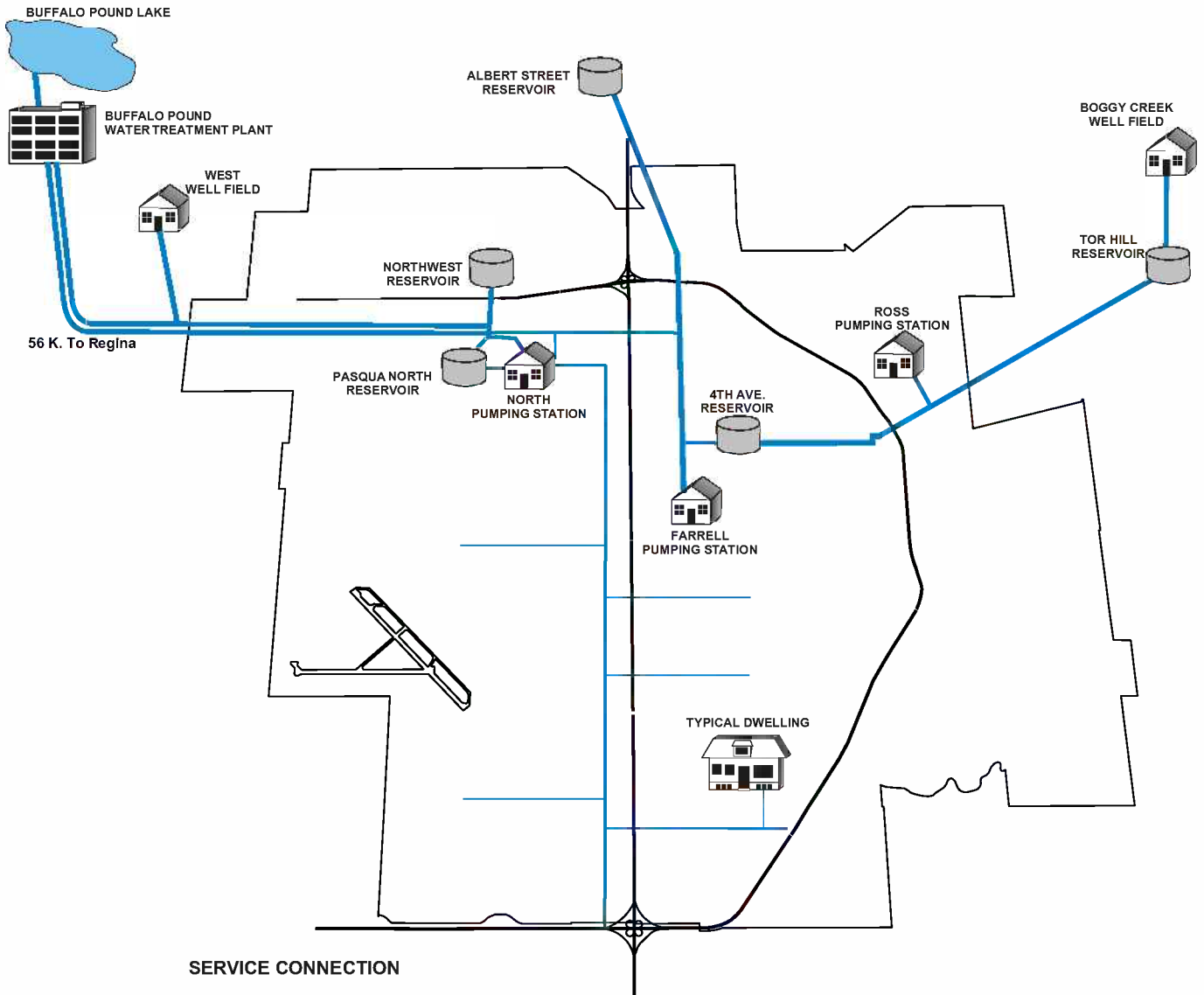

SERVICE CONNECTION

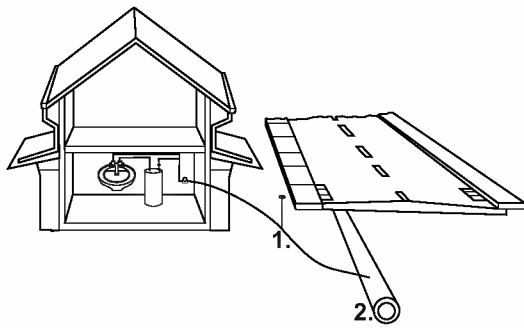

1. Service Connection (Curb Box)
2. Watermain

— Supply System
— Distribution System

Water System Objectives

The Long Term Water Utility Study, initially completed in 1993, covered all aspects of the water system, including projected future water requirements, the condition of the existing system components, and a review of the system operations. The Study was adopted by City Council as the city's long term water supply plan. In 1998, a portion of the Study was updated and resulted in a decision to improve the Buffalo Pound supply pipeline and pumping system rather than construct a ground water treatment plant. A Study update was completed in 2006 and provided recommendations for water system improvements for the next 20 years.

As part of the Study, a number of objectives were established. These objectives continue to guide the water system operations today, and include:

- **Water Quality** – The City adopted the *Guidelines for Canadian Drinking Water Quality, 4th Edition* published by Health Canada as the basis for its water quality objectives. These are the most complete guidelines established in Canada. The standards, adopted by Saskatchewan Environment, regulate the operation of all waterworks in Saskatchewan.

For parameters not included in the *Guidelines*, the City has adopted the most stringent level listed by other authorities. Some parameters are for substances for which there are aesthetic concerns rather than health concerns, such as iron, manganese and hardness. Other parameters are for substances to which health concerns have been linked but not proven, such as aluminum and trihalomethanes.

- **Water Conservation** – An enhanced Water Conservation Program was initiated in 1991 to reduce the per capita water consumption and the short term peak water demand. The City to date has been successful in meeting the targets that were set for the program.
- **Reliability** – The City established an objective for the reliability of delivery, defined as ensuring water will be available within the limits of minimal local disruptions for system maintenance and rare large-scale disruptions due to unforeseen catastrophe. Specific objectives are:
 - Mandatory water rationing should occur less than one year in ten.
 - Service should be restored within 24 hours in the event of local service disruptions such as water main breaks and connection problems. This objective is achieved for 99% of incidents.
 - All reasonable steps should be taken to ensure that large-scale disruptions do not occur. These steps include ensuring that there is sufficient redundancy in the system so that alternate facilities can be used in the event of a failure in part of the system.
 - Alternate power sources must be available in the event of a main power failure.
 - Hydrants should be installed and maintained to meet the requirements of the National Fire Code.
- **Water Pressure** – Water must be delivered to customers under pressure. It is desirable to maintain pressure standards between a minimum and maximum range. The pressure under which water is delivered to a customer depends upon many factors, including the consumption by other customers, pumping capabilities, pipe size, velocity of the water through the system, and the design of the water system.

Water pressure can be controlled to a certain extent through the operation of pumps and other components of the system. However in some instances, system changes may be necessary to meet pressure standards.

As part of the Long Term Water Utility Study, desirable ranges for pressure and velocity were identified and system improvements were recommended where conditions fell outside of these ranges. Work is currently underway to design and construct a second pressure zone to address lower pressures in the north end of the city.

- **Efficiency of Operations** – Electricity used in pumping water is a significant cost. This cost is a factor of the efficiency of the pumps as well as the hydraulics of the system. Pumping operations are regularly reviewed to identify where system improvements or operational changes could reduce electrical costs. Changes are pursued when cost-effective.

Water Supply

Buffalo Pound Lake now provides 100% of Regina's water needs. The water is treated at the Buffalo Pound Water Treatment Plant, which is jointly owned by the cities of Regina and Moose Jaw. It was built in the 1950s in order to provide water for those two cities. The facilities are administered by the Buffalo Pound Water Administration Board, which consists of two members appointed by the City of Regina and one member appointed by the City of Moose Jaw.

Although the plant is operated as a separate entity, there is a high degree of communication and cooperation between the plant operators and the two cities.

On an annual basis, the Board establishes a general water rate. The rate is established on a cost-recovery basis. The 2010 rate has been set at \$204.75 for one million litres, a 5.5% increase over the 2009 rate. The increase is due primarily to rising costs for electricity, increases in unit prices for treatment chemicals, equipment price increases, and increases for wages and benefits.

Since Buffalo Pound Lake is shallow and prone to the growth of algae and other organic materials, treatment of the lake water is challenging. Over the last ten years, the lake water has required higher levels of treatment to provide water that meets the City's water quality objectives.

The City's estimated 2010 cost of water purchased from Buffalo Pound will total approximately \$6.4 million, or about 40% of the total costs of the Water Supply, Pumping and Distribution Program, or about 13% of total Utility costs.

Future planning for the plant must address new and anticipated regulations related to health effects. The review and update of the City's Long Term Water Utility Plan includes a study of the Buffalo Pound Water Treatment Plant. Results of the study include:

- **Disinfection** – The plant uses chlorine for treatment and disinfection. Chlorinating naturally occurring organic material results in the formation of disinfection by-products known as trihalomethanes and haloacetic acids, which are harmful to human health. The Study recommends reducing the use of chlorine if possible in conjunction with the addition of ultraviolet light disinfection which is effective in reducing risks associated with cryptosporidium.
- **Taste and Odour Control** – The plant uses granular activated carbon and powdered activated carbon to control taste and odour generated by algae in Buffalo Pound Lake. The percentage of time that taste and odour control is required has been increasing for a number of years. The Study discusses the performance of a detailed analysis of additional contactors versus additional storage for granular activated carbon but recommended a third screw pump and four additional contactors.
- **Wastewater Residuals Management** – The treatment processes remove particulate matter along with approximately 6% of the total water volume from the lake water. This wastewater must then be treated and disposed to the environment. The existing wastewater lagoons are overloaded. Use of

the Recycle Facilities installed in 1985 was terminated in the 1990s due to cryptosporidium concerns. Recycling could be restored soon after UV disinfection is implemented.

- **Water Stability** – Treated water is slightly corrosive which leads to the softening of concrete tanks in the water treatment plant and the slow deterioration of piping and fittings in the water distribution system which contains metal. Corrosion control in the form of protective coatings for concrete tanks and pH adjustment of treated water is recommended in the Study.

An engineering consultant has been engaged to initiate a review of upgrade concepts identified in the Long Term Planning Study, and to move forward on predesign and detailed design of confirmed upgrades over multiple year capital program.

A Waterworks System Assessment (WSA) was completed for the Buffalo Pound Water Treatment Plant and Regina’s Water System in 2005. WSA’s are required every five years in accordance with Saskatchewan Environment’s 2002 Water Regulations. The WSA evaluates current performance, level of optimization, functionality, capability, efficiency and sustainability of the waterworks and identifies required improvements.

As part of the total water purchase costs the two cities also contribute an amount equal to 10% of the general water charges to a Capital Replacement Reserve used to pay for replacement and upgrading of equipment in the plant.

Costs for major improvements to the plant are shared with the City of Moose Jaw. The cost-sharing ratio is determined by the percentage ownership of each City, which at the present time is approximately 73% for Regina and 27% for Moose Jaw.

Water Purchase Statistics	2005	2006	2007	2008	2009
Purchases (mega litres)	26,799	28,138	28,534	27,868	27,554
General Rate (\$/mega litre)	154.81	158.59	169.47	177.98	194.08
Annual cost of water (\$'000's)	4,148.8	4,462.4	4,835.7	4,959.9	5,348.1
Capital Replacement Program (10% of General Rates) (\$/mega litre)	15.48	15.86	16.95	17.80	19.41
Power Cost (\$/kwh)	0.05400	0.05751	0.06067	0.06370	0.06846
Power Usage (kwh) (000's)	4,895.7	5,948.6	3,071.0	2,783.0	2,568.0

Regina can also draw water from 9 wells located in and around the city. Wells currently are available for emergency water supply in the event of a failure in the Buffalo Pound Water Supply; however, the amount available from the wells is less than the city’s typical daily needs.

The well water meets current regulatory standards but has levels of iron, manganese and hardness that exceed the City’s water quality objectives. These minerals can cause staining on fixtures, as well as the appearance of “discoloured” water. The minerals also cause problems by forming deposits in the water system, requiring more frequent maintenance.

A number of tests are carried out to ensure that the water meets the water quality objectives. Tests include:

- **Water quality** at the Buffalo Pound Water Treatment Plant is extensively monitored. On-line analyzers are used to monitor the major parameters. The water is continually monitored after every treatment stage. Laboratory staff perform over 25,000 analyses per year monitoring 65 different water quality parameters. The cost of these procedures is included in the general water rate for water purchased from Buffalo Pound.

- Tests are also carried out at various points in the City's water supply and distribution system. Regular sampling and testing is done in order to comply with provincial requirements for the operation of the water system, as well as to ensure the City's water quality objectives are met.

Test results show that the water supply meets all regulatory guidelines.

In addition to carrying out testing of treated water, steps are taken to safeguard the water supply. Identification and prevention of possible sources of groundwater contamination is an ongoing process. Saskatchewan Watershed Authority in conjunction with stakeholders completed a Source Water Protection Plan for the Upper Qu'Appelle and Wascana Creek watersheds in 2008.

Water Pumping

Three pumping stations are used to pump water from reservoirs into the distribution system. The operation of all stations must be coordinated along with supplies from Buffalo Pound and other components of the supply system such as the reservoirs. Since electrical costs are a major component of this operation, it is important that the pumps are operated in an efficient manner. Water pumping must also be provided when electrical power failures occur.

In order to coordinate the operation of each station and to operate the pumps in an efficient and reliable manner, system data is required. This information is obtained from a computerized Supervisory Control and Data Acquisition (SCADA) system.

Water Distribution

The water distribution system consists of buried pipelines made of cast iron, AC, or PVC. Steel is used for large supply mains exceeding 500 mm in diameter. Cast iron pipe was installed from 1904 until the 1940s. AC was used throughout the 1950s, '60s and '70s. AC and PVC pipe comprise 55% and 30% respectively of the 1,070 kilometre of mains in the system as of 2008. Approximately 107 kilometres of cast iron pipe has been replaced with PVC pipe since 1980. Some cast iron pipe remains due to location and size considerations (intersections, 400 mm diameter and over) and will be replaced as the need and opportunity arises. PVC pipe repair costs are virtually nil. The replacement of cast iron pipe with PVC pipe has allowed for significant savings in maintenance repairs.

Watermain breaks are a primary cause of water service disruptions, water losses and discoloured water. The frequency of breaks is a function of the pipe materials. The distribution of each material in the system and its failure rate is as follows:

Type of Pipe	Length (km)	Percentage of Total System Length (%)	Failure Rate (breaks/km)
Cast Iron	20	1.9	0.3
Asbestos Cement	550	51.4	0.3
PVC	310	29.0	-
Steel	165	15.4	-
Other	25	2.3	-
Total	1,070	100.0	

Note:

Lengths based on 2008 Benchmarking data. The failure rate is calculated based on break data from 2000 to 2009.

Watermain Statistics	2005	2006	2007	2008	2009
Main Leaks Repaired (#)	65	183	206	179	174
Average Unit Repair Cost (\$)	8,705	6,418	7,415	10,012	9,382

Note:

The variance in the average unit cost in some years is the result of more locations requiring more expensive replacement methods.

The existing water distribution system has a number of “dead ends”, which cause problems in the operation of the system. In order to maintain uniform pressures in the system, ensure high water quality, and provide adequate flow to fire hydrants, dead ends should be avoided. Where possible, the watermains should be “looped”, or connected to another line. This is possible in fully developed areas where there are other lines with which to connect. However, it is not practical to do this in areas on the edge of the city or in cul-de-sacs. The City has an ongoing capital program that addresses the reduction of the number of dead ends, thereby increasing the security of the overall system.

The water distribution system includes over 8,000 valves. The valves should be in working order to shut off the water for repair and when flushing watermains. The valves are checked periodically and repaired or replaced as necessary. In many cases, the valve is functioning properly, but the casing surrounding the rod used to turn the valve is damaged or filled with dirt. An alternate method of excavation, called hydro-excavation, uses high pressure water and vacuum to loosen and remove soil for repair access. The method is quicker and leaves a smaller excavation. The following unit costs for valve repairs are associated with the traditional excavation methods only.

Watermain Valve Statistics	2005	2006	2007	2008	2009
Valves Replaced (#)	28	24	24	39	30
Unit Replacement Cost (\$)	5,902	6,416	9,559	6,878	7,849
Valves Repaired (#)	78	67	90	81	13
Unit Repair Cost (\$)	1,429	1,760	1,182	2,062	7,048

The City operates a system of fire hydrants in order to provide water for firefighting purposes. The National Fire Code sets out standards for fire hydrants, and indicates that regular maintenance is required. The City uses *Water Supply for Public Protection – A Guide to Recommended Practice (1981)* published by the Fire Underwriters Survey as its standards for fire hydrant inspection and maintenance. These standards include checking hydrants on a regular basis to ensure they are functioning properly and available for use in the event of a fire; repairing and replacing any malfunctioning hydrants; repainting each hydrant every five years; and installing hydrants in new areas to ensure a hydrant is available within the specified distance of all buildings. The parts from damaged or obsolete hydrants taken out of service are salvaged and reused whenever possible.

Hydrant Statistics	2005	2006	2007	2008	2009
Hydrants in Service (#)	3,991	4,003	4,058	4,125	4,243
Hydrant Replacements (#)	15	9	14	18	16
Unit Replacement Cost (\$)	9,271	9,565	11,499	11,115	10,337

The above unit cost is for an emergency replacement, which includes the cost of a hydrant lead pipe, and temporary water supply to customers while the water is turned off.

Work done on service connections range from minor repairs at the curb box, to the repair or replacement of the entire service connection. Water must be turned on and turned off at the customer site for reasons such as transfer of ownership of a home, new customers, breaks in waterlines on the customer's property and unpaid accounts. The water is turned on and off by turning a rod attached to the valve beneath the soil surface. At times, these rods and valves (curb boxes) may first have to be repaired.

One 24-hour emergency service crew handles water leaks, complaints and other trouble calls.

Service Connection Statistics	2005	2006	2007	2008	2009
Connection Leak Repairs (#)	267	374	354	301	285
Unit Repair Cost (\$)	3,599	3,499	5,128	5,448	4,917
Curb Box Repairs (#)	669	604	660	617	544
Unit Repair Cost (\$)	907	1,008	1,087	1,199	809

The City has an Automated Meter Reading (AMR) system which is used to obtain monthly meter readings. The reading success rate is over 99%. Malfunctioning equipment is repaired or replaced as necessary. New meters are installed for new buildings.

Meter Installation and Repair Statistics	2005	2006	2007	2008	2009
Meters in Service	60,731	61,500	62,008	62,815	63,466
Meters Installed	710	903	1,023	967	1,158
Meters Overhauled	560	421	1,029	420	754
Service Calls	5,292	5,157	4,448	4,944	4,092

Water Consumption

The 2010 budget is based on an estimate of billable water consumption of almost 23.5 million cubic metres. About 56% of the consumption (13.2 million cubic metres) is for residential properties, 11% (2.6 million cubic metres) for multi-residential properties, and 33% (7.5 million cubic metres) is for non-residential properties.

The City has had a Water Conservation Program since 1985 and initiated an enhanced program in 1991. The primary goals of the program are to reduce the average per capita water consumption and the peak day water use. The following table provides information on the total water supplied and water use.

Water Supply and Use	2005	2006	2007	2008	2009
Total Water Supplied (mega litres)	26,799	28,158	28,534	27,956	27,556
Average Water Use per capita per day (litres)	377	400	393	381	379
Winter Water Use per capita per day (litres)	350	371	348	345	337
Summer Water Use per capita per day (litres)	414	487	458	434	453
Peak Day Water Use (mega litres)	128	127	137	122	134

Note:
2009 per capital use is based on a population of 199,000.

The Water Conservation Program continues to meet the goals that were initially set. The following table provides the history of metered water consumption.

Metered Water Consumption
(Million Cubic Metres)

<u>Year</u>	<u>Metered Water Consumption</u>
1994	23.1
1995	23.4
1996	24.9
1997	25.5
1998	24.4
1999	23.9
2000	23.3
2001	24.3
2002	24.0
2003	25.0
2004	22.4
2005	21.8
2006	23.1
2007	23.7
2008	22.7
2009	22.1

Water Quality Monitoring

Water quality monitoring activities include:

- Administering the Permit to Operate Water Works for operation of the water system, including water quality monitoring of all water sources and the distribution system, and maintaining records related to the safety and operation of the water system.
- Carrying out supplemental testing to gather water quality data from the water distribution system.
- Communicating information about water quality to the public.
- Efforts to protect the City's water source at Buffalo Pound Lake and the Regina area aquifers.

Water Loss Reduction

All water utilities experience a certain amount of water loss. Water loss is the sum of water leaks plus water usage that is not metered and thus not billed to a customer. Water used to suppress fires and some irrigation are examples of water use that is not metered. Water lost through watermain breaks is an example of leakage and is part of the "unavoidable real losses" from the water distribution system.

In 2006, the City of Regina changed the method for reporting water loss. The International Water Association (IWA) Water Loss Task Force has produced an international best practice standard approach for water balance calculations and the estimation of water loss. This best practice has also been adopted by the American Water Works Association (AWWA) and by the Federation of Canadian Municipalities (FCM) InfraGuide Best Practice "Water Use and Loss in Water Distribution Systems".

The international best practice performance measure advocated by the IWA and AWWA is the Infrastructure Leakage Index (ILI). The ILI is defined as the ratio of Current Annual Real Losses (Real Losses defined as physical water losses from the pressurized system up to the point of customer consumption) to the Unavoidable Annual Real Losses (UARL defined as a theoretical reference value representing the technical low limit of leakage that could be achieved if all of today's best technology could be successfully applied). The ILI is a highly effective performance measure because it is:

- Based on a calculation that has been tested globally;
- Unit-less and based on real water loss;
- System specific taking into account operating pressure, service connection length, pipe condition and water meter location; and
- Comparable to an international data set.

To date, 27 municipalities in Canada that are participating in water system benchmarking have or are undertaking this method of determining an (ILI) index for their water distribution systems. The ILI is a highly effective performance indicator for comparing (benchmarking) the performance of utilities in operational management of real losses.

The 2008 calculated ILI of 2.96 for the City of Regina is within the "Good" Technical Performance Range of 2.0 to 4.0, but there is potential for marked improvements. For comparison purposes an ILI index of 1.0 to 2.0 is within the "Excellent" Technical Performance Range and indicates that further water loss reduction, although possible, may be uneconomical. 2009 data is not yet available.

A Leakage Management Project was initiated in 2005 in Regina in cooperation with the National Research Council. The final report on the project is expected for release in the spring of 2010.

Water Volumes (million cubic metres)	2005	2006	2007	2008	2009
Total Water Supplied	26.8	28.1	28.5	28.0	27.6
Billed Consumption	21.8	23.5	23.7	23.2	22.6
Unaccounted Water	5.0	4.6	4.8	4.8	5.0
Unaccounted Water as a Per Cent of Total Water Supplied (%)	18.66	16.37	16.84	17.14	18.12
Infrastructure Leakage Index	2.97	2.35	3.04	2.96	n/a

Water Conservation Program

The Water Conservation Program consists of identifying information that should be provided to the public on methods of conserving water, and communicating the information by means such as:

- Web page information.
- Xeriscape landscaping information available on the website.

Cross Connection Control and Backflow Prevention Program

Water quality can be compromised by the introduction of contaminants into the distribution system. This can occur wherever there is a cross connection, which is a link between the drinking water supply and a source of contamination such as a pesticide container on a garden hose or a boiler filled with anti-corrosion chemicals. Various conditions can cause backflow and/or backpressure in the water supply system. This can cause the drinking water to move in the opposite direction and take with it any materials

it is in contact with or mixed with. The result is the water supply to a building or neighbourhood becomes polluted or contaminated.

The Cross Connection Control and Backflow Prevention Program was established in 1996 to reduce the possibility of contamination from such causes. Since the program was established, all new facilities have been reviewed for backflow prevention requirements through the building permit process. All existing commercial, institutional and industrial facilities are being inspected by the City. Any backflow requirements are identified and a one-year time frame given to become compliant.

The four primary components of the program are:

- Public education and awareness.
- Inspections of commercial, industrial and institutional facilities.
- Administration of the annual testing of testable backflow prevention assemblies.
- Review of appropriate building permits for new facilities.

Since the inception of the program, 2,044 facilities have been inspected, and over 3,500 backflow prevention assemblies have been installed.

Cross Connection Control and Backflow Prevention

Statistics	2005	2006	2007	2008	2009
Facilities Inspected	167	95	5	8	43
Building Permits Reviewed	78	54	71	77	76
Backflow Prevention Assemblies Installed	250	1,450	223	253	445

Wastewater

Initiatives for 2010

- Engineering pre-design work will start for the wastewater treatment plant upgrade/expansion project. Also participate with the Ministry of the Environment (MoE) on Duty to Consult with First Nations regarding plant upgrade/expansion.
- Continue to convert wastewater treatment plant engineering drawings into digital format to improve efficiency
- Provide engineering, detailed design and tendering over a two year timeframe for a fully renewed wastewater screening system, and flow security at the McCarthy Boulevard Pumping Station. This project incorporates integrity improvements including bypass pumping, valving, instrumentation, controls, and auxiliary equipment improvements, and code upgrades.
- Design and install a new water supply and fire suppression system to the Wastewater Treatment Plant.
- Undertake a pre-design and detail design of a new liquid waste hauler receiving station.
- Design a replacement sludge dewatering system including tendering and installation of the new equipment.
- Initiate planning design and construction of a new maintenance building at the wastewater treatment plant.
- Participation will continue as a member of the Wascana Upper Qu'Appelle Watersheds Association Taking Responsibility (WUQWATR) and the Wascana Creek Advisory Committee.
- Complete the cleaning and inspection of several siphons.
- Expand the grease inspection program to include oil grit separators for automotive service businesses and parking lots.
- Complete 2010 inspection and rehabilitation programs for the wastewater collection system.
- Purchase a combination jetting/vacuum/hydro excavating truck.
- Refurbish critical piping within the plant.
- Complete the domestic lift station to the neighbourhoods known as the Creeks, the Greens on Gardiner, and portions of the Towns.
- Continue assessment and rehabilitation or replacement of existing lift stations.
- Clean and inspect domestic mains outside of the integrated works locations under a proactive cleaning and camera program.
- Initiate Phase 2 of the water and sewer infrastructure management strategy.
- Undertake Southeast Sector Serviceability Review for long term wastewater services.

- Review the operations of the Westhill Lift Station and plan for improvements as required.

Status of 2009 Initiatives

- Equipment and programming for an automated tracking and billing system for liquid waste haulers utilizing McCarthy Boulevard Pumping Station will be deferred to coincide with commissioning of a new liquid waste hauler station in 2011.
- A partial inspection of critical areas of the concrete 54" diameter forcemain delivering wastewater to the primary treatment plant was accomplished in 2009.
- The replacement of the failed forcemain between McCarthy Boulevard Pumping Station and the Wastewater Treatment Plant was completed.
- The methane gas utilization project at the wastewater treatment plant will be incorporated into the main Wastewater Treatment Plant Expansion project.
- Completed the serviceability study on the ultraviolet disinfection equipment.
- Engineering pre-design of a renewed wastewater screening system at McCarthy Boulevard Pumping Station was completed.
- Construction of two domestic lift stations with on-site storage facilities continued in 2009.
- Completed the inspection and rehabilitation of wastewater collection system for the 2009 program.
- Completed the detailed design and construction of the lining project for the Wascana Valley Trunk from Winnipeg Street to Albert Street.
- Identified areas beyond integrated works locations for rehabilitation to proactively address areas of concern. Locations were carried over to 2010 due to budget constraints.
- Initiated the City-wide wastewater study which will convert the current modelling system to a more dynamic platform capable of evaluating the system under a broader range of flow conditions.
- Completed Phase 1 of the infrastructure management strategy as a continuation of the overall infrastructure management initiative for underground utilities.
- Initiated development of a service level classification frame work for the wastewater collection system in partnership with the City of Saskatoon.
- Construction of wastewater pump stations and forcemains for Southeast and Southwest Sector development were initiated in 2009 and are nearing completion.
- Northeast Sector Serviceability Study is underway and completion is expected in 2010.
- Provision for wastewater collection from the Global Transportation Hub (GTH) was initiated in 2009. Completion of the wastewater collection system, including a lift station, for the first phase of the GTH is expected in 2010.

Wastewater System Overview

The wastewater collection and treatment system collects sewage from residential, institutional, commercial and industrial customers in the city. Wastewater treatment and final effluent meet provincial environmental standards. Service goals include:

- Collecting domestic, commercial and industrial wastewater in the City and reliably delivering it to wastewater treatment facilities.
- Producing a treated wastewater effluent that is biologically and physically safe for the environment and which meets the requirements of the provincially issued operating permit.
- Ensuring solids removed from the wastewater are treated and disposed of in an environmentally responsible manner.

Components of the wastewater system shown in the map on the next page include:

- **Service Connections** – Building plumbing systems are attached to the wastewater collection system by a service connection pipe. The City owns and is responsible for the maintenance of the service connection pipe on the “City side” of the property line.
- **Collection Mains and Trunk Mains** – The service connection pipes are attached to wastewater collection mains which are typically 200-250 mm in diameter. The collection mains drain into trunk mains which are 300 mm or more in diameter.
- **Manholes** – Over 15,000 manholes provide access to the wastewater collection system for maintenance and repair.
- **Lift Stations** – Wastewater flows through the collection system by gravity. In low-lying areas in the city, lift stations must be used to pump the wastewater to collection and trunk mains at a higher elevation. Wastewater then continues to flow by gravity from that point eventually reaching the McCarthy Boulevard Pumping Station. There are 17 lift stations in the wastewater collection system.
- **McCarthy Boulevard Pumping Station** – All wastewater collected in the City flows to the McCarthy Boulevard Pumping Station. The station provides screening and continuous transfer of wastewater from the collection system to the wastewater treatment facilities five kilometres west. The McCarthy facility is capable of transferring wastewater at up to five times the average daily rate. The station is also the existing location where commercial septic tank haulers offload into the wastewater system.
- **Wastewater Treatment Plant** – The plant processes wastewater through four stages of treatment:
 - Primary treatment removes sand, grit and organic material from the sewage.
 - Secondary treatment reduces dissolved organic material through the use of aerated lagoons.
 - Tertiary treatment removes phosphorus, algae and suspended solids by using aluminum sulphate and polymer.
 - Ultraviolet light is used to disinfect the effluent before it is released into Wascana Creek.

WASTEWATER SYSTEM

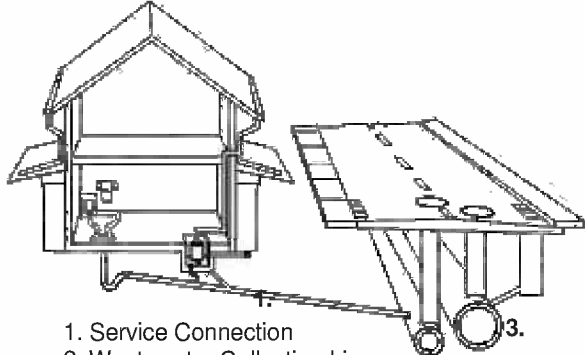
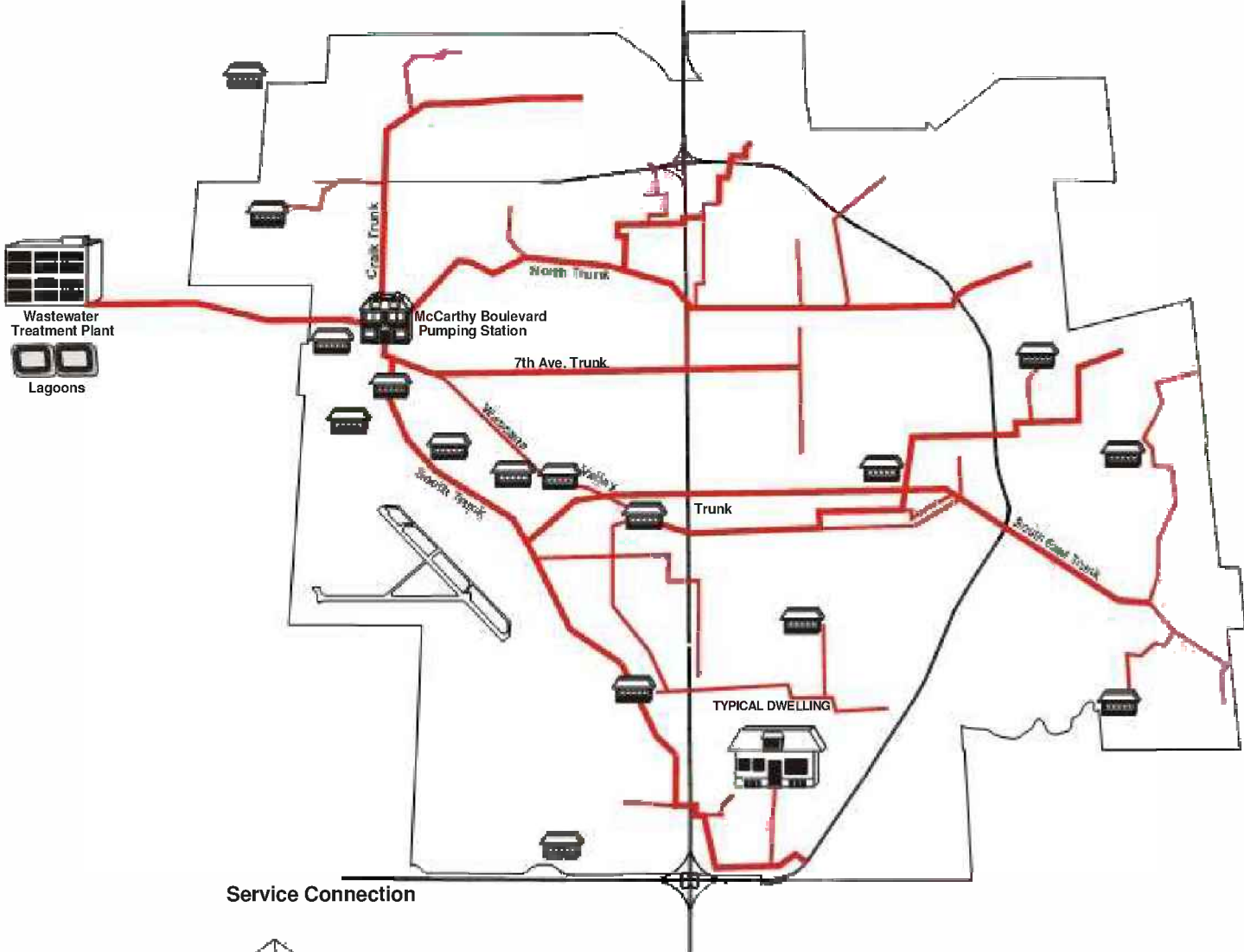

- 1. Service Connection
- 2. Wastewater Collection Line
- 3. Drainage Line (Storm Sewer)

— Wastewater Sewer Main
 Lift Station

Wastewater System Objectives

The provision of wastewater collection and treatment services is critical to the health and environment of the citizens of Regina and surrounding area. Objectives for wastewater collection and treatment are:

- **Quality of Sewage Effluent** – Treated wastewater from the City's wastewater treatment plant is discharged into Wascana Creek, which flows into the Qu'Appelle River upstream from the town of Lumsden. Federal and Provincial agencies establish criteria for sewage effluent that each wastewater facility in the province must follow. The major criteria are total phosphorus, fecal coliform bacteria, pH, biological oxygen demand and suspended solids in the treated effluent discharged to Wascana Creek.
- **Reliability of the Collection System** – Improperly functioning wastewater collection systems cause inconvenience, health and safety concerns. Problems such as blockages and leaks can result from grease and solids build-ups, deterioration of pipes, sags and breaks in wastewater collection lines and at connections caused by shifting soil, tree roots and foreign materials in the lines. To prevent these problems a regular inspection and maintenance program is required.
- **Separation of the Drainage System from the Wastewater Collection System** – The wastewater collection and treatment system is adequate to handle the day-to-day wastewater flows from the city. During rainfall and snow melt events, drainage water enters the wastewater collection system through basement sump pits connected to weeping tile drainage, catch basins inadvertently connected to the wastewater collection system, and infiltration through pipe cracks and openings such as wastewater manhole covers. Reducing the amount of drainage water entering the wastewater collection system can postpone large expenditures required for trunk mains and treatment plant capacity expansions. Work is being done to reduce infiltration to both new and existing wastewater mains and trunks.
- **Odour Control** – One of the by-products of wastewater collection and treatment is odour. Such odours are unpleasant for nearby residents and staff. Reduction of odours is accomplished by the use of containment, chemicals and aeration lagoons. The aeration equipment at the treatment facilities injects oxygen into the wastewater, preventing a septic environment that produces strong odours.
- **Efficiency of Operations** – Electricity is primarily required to operate pumps and aeration blowers. Chemicals such as aluminum sulfate and polymer used to remove phosphorus are a significant cost of operating the wastewater treatment plant. To minimize costs, it is important to make effective use of chemicals required to meet effluent targets. The most efficient use of electricity, chemicals and other inputs is accomplished by automatic process control and laboratory based performance information at all stages of the treatment process.
- **Maintaining Treatment Capacity** – Regina uses five aeration lagoons in its secondary treatment process. Over the years, as solids settle to the bottom of the lagoons and aeration systems deteriorate, capacity is diminished. To maintain treatment capacity, new lagoons must be built or old lagoons must be refurbished.

Wastewater Collection

To identify and prevent problems in the wastewater collection piping, the lines require inspection and cleaning. Locations with chronic problems are cleaned more frequently with high-pressure water to dislodge grease and other matter. In conjunction with jet cleaning, sewer lines should be inspected with cameras for physical soundness.

Sewer Maintenance Statistics	2005	2006	2007	2008	2009
Lines Cleaned - Jet Cleaning Program (m)	67,627	47,426	57,840	45,319	32,153
Average Cost (\$/m)	1.23	1.21	1.68	1.62	1.52
Main Repairs (#)	9	12	10	9	7
Average Cost (\$/repair)	6,755	6,517	6,482	15,148	10,994
Manhole Repairs (#)	71	70	80	66	120
Average Cost (\$/repair)	675	1,045	836	966	1,389

Service connections that break down or block too frequently are either repaired or replaced.

Wastewater Connection Statistics	2005	2006	2007	2008	2009
Connection Repairs (#)	41	38	54	50	53
Average Cost (\$/repair)	5,177	4,354	4,279	4,900	4,234
Connection Replacements (#)	92	103	92	87	56
Average Cost (\$/replacement)	5,669	5,829	7,091	9,301	9,888

The wastewater collection system includes the operation of 17 lift stations. Electricity is a significant cost in operating the stations. Ongoing electrical and mechanical equipment maintenance is required, in addition to general maintenance on the station buildings and grounds.

Wastewater Treatment

The McCarthy Boulevard Pumping Station pumps all wastewater to the Wastewater Treatment Plant. High reliability and capacity are critical to ensure this facility does not cause sewer collection system backup. One of two electric pumps handles normal daily flows while three high capacity diesel pumps handle extreme flow events, which happen when stormwater infiltrates the sewer system during rainstorms or sudden snow melts. Screenings removed at the station are disposed of at the sanitary landfill.

McCarthy Boulevard Pump Station Statistics	2005	2006	2007	2008	2009
Total Annual Flow (Million litres)	25,721	25,150	25,357	25,142	25,393
Bypass Flows (Million litres) (Target:0)	-	-	-	-	-
Screening Removal (tonnes)	137	105	103	116	173

All wastewater is treated at the primary treatment plant. The plant uses settlement to remove solids from sewage. The City has established a target of 60% for suspended solids removal.

Treated sludge from the primary treatment process is stock piled on site for subsequent disposal. A target of >30% solids in the sludge has been set. A higher number means drier sludge, which reduces hauling costs.

Primary Treatment Statistics	2005	2006	2007	2008	2009
Suspended Solids Removals (%) (Target>60.0)	62.0	60.6	61.8	62.0	60.7
Biological Oxygen Demand Removals (%) (Target>35.0)	33.0	34.3	30.5	32.6	31.9
Solids in Cake Sludge (%) (Target>30.0)	33.0	33.7	32.2	31.0	30.1
Tonnes of Sludge (Dry Weight)	1,655.0	1,568.0	1,619.0	1,438.0	1,471.0

The secondary treatment process that removes sewage organics measured as biological oxygen demand involves the use of aerated lagoons. Large blowers are used to force air through diffuser pipes and into the wastewater. Electricity is a major cost of this function. To prevent septic conditions and thereby reduce odours, a minimum of three parts per million dissolved oxygen is maintained in the lagoons. Higher oxygen transfer efficiencies reduce energy costs.

Secondary Treatment Statistics	2005	2006	2007	2008	2009
Oxygen Transfer Per Cent Efficiency					
Lagoon 1 South	3.0	4.2	4.2	4.2	4.2
Lagoon 2A	6.3	6.5	6.5	6.5	6.5
Lagoon 2/3	4.2	4.9	4.9	4.9	4.9
Average Lagoon Dissolved Oxygen Level mg/l	5.3	4.7	4.3	4.8	4.5

The tertiary treatment plant removes phosphorous, algae, suspended solids, bacteria and biological oxygen demand (BOD) from the lagoon effluent prior to disinfection and release of the treated effluent to Wascana Creek. The major expenditure is for liquid alum.

It is desirable to maintain a low alum to phosphorus ratio to meet criteria established by Saskatchewan Environment. In wet years, plant flow capacity limitations degrade performance and partial bypassing may be required. The average effluent phosphorus requirement is ≤ 1.00 parts per million.

Tertiary Treatment Statistics	2005	2006	2007	2008	2009
Alum to Phosphorus Removal Ratio (Target <33.0)	34.7	25.6	26.1	29.7	31.2
Average Effluent Phosphorus (Target ≥ 0.90 & ≤ 1.00)	0.93	0.99	0.97	0.98	0.99
Bypass Flows (Target 0) ML	-	-	-	-	-

Disinfection of final effluent water prior to its release to Wascana Creek is performed by ultra violet light to reduce health risks to downstream water users.

Disinfection Statistics	2005	2006	2007	2008	2009
Average of Fecal Coliform Geometric mean counts/100 ml (weekly geometric mean permit is 100/100 ml)	20.4	9.5	7.8	4.6	9.3

The wastewater treatment plant laboratory does regular daily, weekly, and monthly tests at all stages of treatment to ensure effectiveness. Research and pilot treatment projects are also carried out. Testing is routinely carried out for over 50 different parameters. Samples are taken from 20 different sites on the Wascana Creek and the Qu'Appelle River system. Records of all tests and plant performance are maintained and distributed.

Test and Plant Record Performance	2005	2006	2007	2008	2009
Lab Analysis (#)	25,917	25,518	26,613	28,242	26,323
Treatment \$/Million Litres	175.95	184.92	192.28	198.73	211.57
Treatment \$/Tonne of Contaminants Removed	435.20	447.56	446.21	456.97	476.37
Treatment \$/Capita	23.47	24.12	25.04	27.07	27.41
Overall Contaminants Removed (%) Target > 90%	86.5	87.4	87.2	87.9	94.9

Wastewater Service Connection Refund Program

When customers report problems such as slow draining fixtures, the City will, during normal business hours, clear the connection to the sewer main. During other hours, customers are instructed to contact a sewer service company to determine the nature of the problem and to remedy it. Upon customer presentation of a paid bill, with a complete description of the problem from the sewer service company, the City will provide partial or full reimbursement if a connection obstruction or back up occurred as a result of:

- A breakdown or severe sag in the service connection pipe on the City side of the property line.
- Blockage due to tree roots from trees on City property.
- Blockage due to tree roots from privately owned and City owned trees.
- A blocked wastewater collection main.

The total cost of reimbursements for 2009 is \$139,779 (2008, \$127,152).

Wastewater Service Refund Statistics	2005	2006	2007	2008	2009
Reimbursements (#)	960	1,200	1,160	1,097	1,095
Average Reimbursement (\$)	91	97	108	116	128

Drainage

Initiatives for 2010

- Construction of the Harbour Landing inverted siphon is expected to begin in spring 2010 with completion in the fall. The siphon will provide storm water management for the southern end of Harbour Landing. The Harbour Landing storm water system will allow storm water drainage from the Highway 1/Lewvan interchange and from the agricultural areas to the south.
- South West Quadrant Detention (Victoria Avenue Interchange). This detention will improve the desired drainage level of service in the Glen Elm, Rothwell Place and Glencairn area. Predesign is already completed. Design and construction to start in 2010.
- The City will provide drainage system to the Greens on Gardner and the Creeks subdivision including construction of the City's first sedimentation pond, which will provide not only detention, but will improve storm water quality prior to entering the major drainage system.
- Dorothy Street Storm Channel Crossing Upgrade. This project will upgrade the storm channel crossing at Dorothy Street. Currently, the channel is experiencing erosion problems. Addressing the problems early is important in order to prevent costly structural damage.
- Highland Park/Cityview (Area 13A) pre-design will be undertaken to more fully develop the project upgrades identified in the 'Masterplan Drainage Study Area #13'; to assess additional long term options and to evaluate the effectiveness of the proposed upgrades for larger storms. Design and construction will follow based on the recommended upgrades of the pre-design. Area 13A has been identified as one of the top five drainage problem areas in the city.
- Inspection and trenchless rehabilitation of drainage mains is projected to be the same as last year, which was 15 km.

Status of 2009 Initiatives

- Construction of a major drainage facility known as the Harbour Landing Drainage Channel was initiated in 2008. Construction continued into 2009 and is expected to be completed in 2010.
- The Ring Road Lift Station construction is approximately 95% complete. Items left for construction include an appropriate power generator to accommodate the pumps and programming of the station.
- Stewart Russell Detention Upgrade Project is approximately 80% completed. Construction will recommence at the end of April/May, 2010 and be completed by end of September 2010. Items left for construction are: irrigation (20%), electrical (SCADA set-up), concrete restoration (25%) and landscaping/seeding.
- Inspection and trenchless rehabilitation of drainage mains is completed for 2009 program.
- Drainage Master Study is near completion. The study focuses on the adequacy of the creeks, drainage channels and detention/retention ponds in handling runoff from the 17 subdrainage areas in the City.
- Dieppe Drainage Project Phase III (stormwater ditch west of Courtney Street - west of the back alley along Courtney Street) is completed.

- Provision for regional storm water management for the Global Transportation Hub (GTH) was initiated in 2009. Completion of the stormwater system is expected to be completed in spring 2010.

Drainage System Overview

The drainage system collects water from rainfall and melting snow in and around the City and conveys it to Wascana and Pilot Butte Creeks. The system serves over 60,000 residential and commercial properties. Service goals include:

- Collecting and controlling drainage water within the city to minimize inconvenience, property damage and danger to the public.
- Monitoring the potential for flood conditions in Wascana Creek and the drainage channels and carrying out flood control measures as required.

The **Minor Drainage System** consists of the underground piping system that collects and transports small to medium amounts of drainage from rainfall, snow melt and minor storms. Components of the minor system include:

- Catch Basins – Over 25,000 catch basins located in streets and open space areas collect water and direct it into the drainage lines. Catch basins are designed to keep sand, silt and other matter out of the piping system by causing it to settle to the bottom of the catch basin.
- Lines, Mains and Trunks – There are approximately 700 kilometres of drainage lines located beneath streets. Lines and mains range from 200 mm to 1200 mm in diameter, with trunks over 1200 mm.
- Manholes – Over 15,000 manholes provide access to the system for maintenance and repair.
- Lift Stations – Drainage water flows through the system by gravity. There are low-lying areas where lift stations are used to pump the drainage water to a higher elevation. The water flows into a lift station at a low elevation, and is pumped to a higher level where it continues to flow through a pipe or channel. There are 13 lift stations in the drainage system.

The **Major Drainage System** is used when drainage water exceeds the capacity of the minor system and must flow over land. The major system is designed so that water will flow down roadways and land easements. Components of the major system include:

- Graded Roadways, Land Easements, Swales, and Lots – In order for the runoff water to flow over land to a point where it can be collected, the surface area must be properly sloped.
- Dry Bottom Detention Facilities – These are lower land areas constructed in open space areas such as parks. The detention facility contains outlets to and from the minor system. During periods of heavy rainfall, water that would otherwise overload the minor system enters the detention facility and is stored temporarily. The water from the detention facility then flows back into the minor drainage system at a later time when flows have gone down.
- Lake (or Wet) Retention Facilities – Lakes such as the ones in Lakeridge and Windsor Park are similar to dry bottom detention facilities, except they normally contain water all year for aesthetic reasons. When the minor system is overloaded, the water in these ponds rises, and then drops when the excess water flows back into the minor drainage system.

- **Underground Detention Tanks** – Underground detention tanks are also used, particularly in some of the downtown areas, to store excess water temporarily until it can be accommodated by the minor drainage system.
- **Drainage Channels and Creeks** – Drainage water empties into the drainage channels or Wascana Creek. The drainage channels function as very large drainage lines, with earthen banks used to control the water rather than enclosed pipelines. The drainage channels carry the runoff to Wascana Creek. Drainage from the Rowatt Flood Control Project south of Regina flows to Wascana Creek through constructed channel within the City Limits.

Although the major and minor systems are described as separate systems, they are part of an overall drainage system and must work in conjunction with each other. The systems are depicted in the map on the next page.

Drainage System Standards

Standards for drainage system design are normally expressed in terms of the size and type of storm a system can theoretically handle. For example, a drainage system may be designed to handle a 1:5 year storm, which means that it can handle the size of storm that statistically only occurs once in five years in the area. A drainage system designed to handle a 1:100 year storm would be able to handle the size of storm that statistically occurs once in 100 years in the area.

Statistical information is obtained from the Atmospheric Environment Service of Environment Canada to determine storm sizes. In the past, rainfall data was only available from the airport, but three additional data collection points have been added around the City since rainfall can vary significantly by area. Computer modelling is then done to determine the size of other storms.



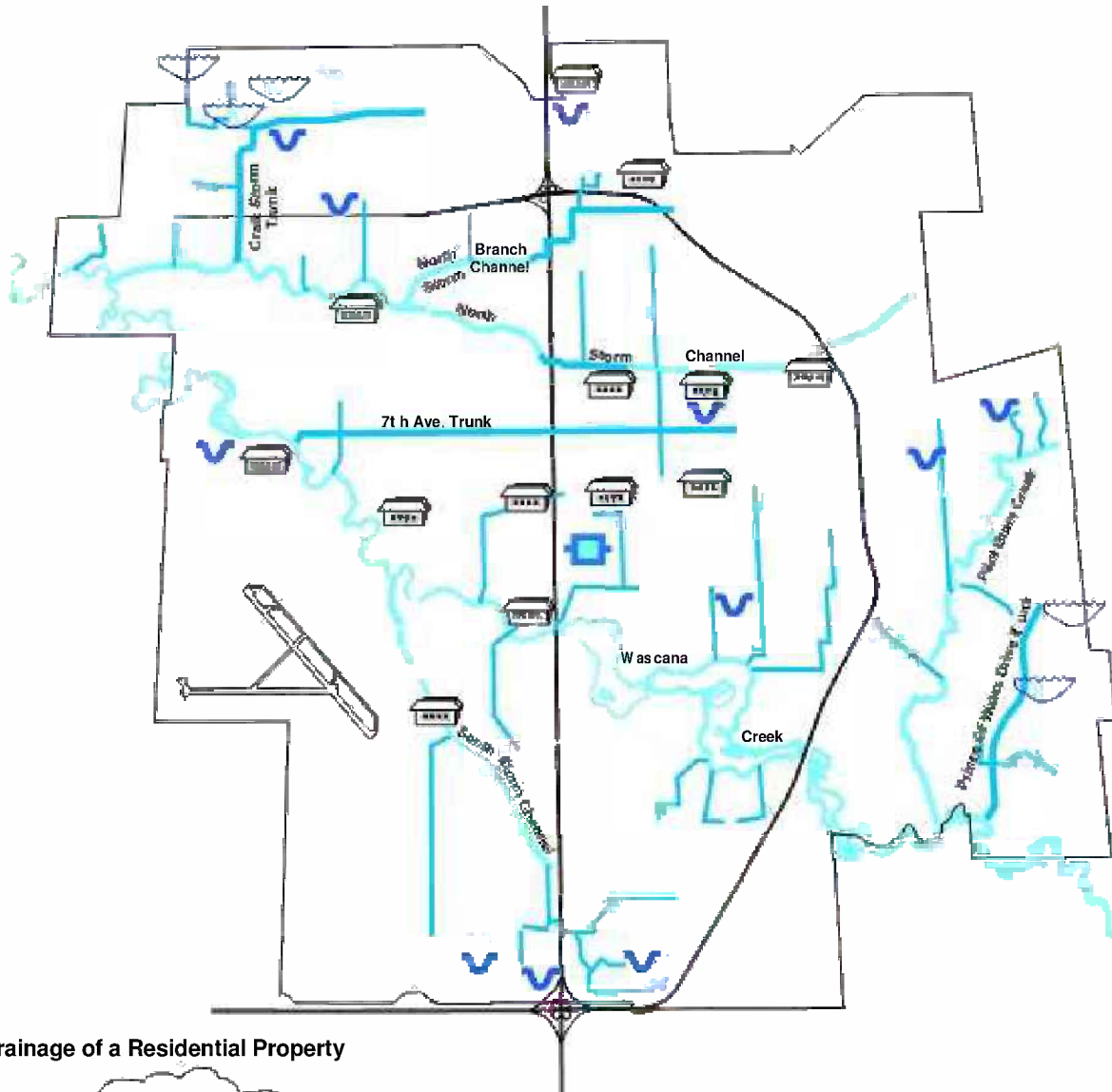

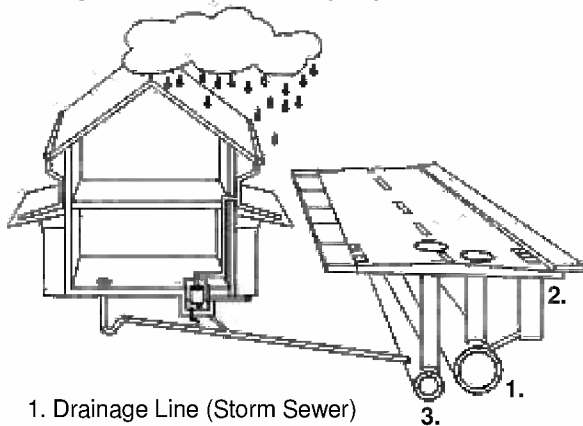

DRAINAGE SYSTEM



Drainage of a Residential Property



1. Drainage Line (Storm Sewer)
2. Catch Basin
3. Wastewater Collection Line

-  Lift Station
-  Retention Pond
-  Dry Bottom Detention
-  Underground Detention
-  Storm Sewer Trunk Main
-  Storm Channel

The following are some of the major rainstorms that have occurred in Regina over the past 30 years:

June 1975	1:25 year storm
July 1983	1:100 year storm (108 mm of rain in four hours)
June 1994	1:25 year storm
August 1995	1:25 year storm (severe hail)
July 2001	1:100 year storm (50 mm in one hour)
August 2004	1:100 year storm (76 mm in one hour)

Factors examined in determining the effective “size of storm” include:

- Total rainfall volume.
- Intensity of rainfall – a storm that drops 100 mm of rain in one hour is much more difficult to handle than one that drops 100 mm over six hours.
- Previous rainfall – if the ground is saturated before the storm, no additional water can soak in. Flows in the drainage system are therefore greater.

Standards for drainage systems have been raised over time, and have been applied to new developments. However, it is very costly to retroactively apply higher standards to existing development. Details of the standards include:

- **New Development Standards** – The “minor” drainage system consists of catch basins and underground lines that quickly collect and transport water. The “major” drainage system, consists primarily of aboveground facilities such as roadways, easements, swales, and detention and retention facilities that can handle larger volumes of water.

For new developments in the city, minor systems must be designed to handle a 1:5 year rainfall event. This corresponds with the general standard used across North America. While a higher standard would provide a higher level of service, the cost to construct underground facilities to handle larger storms is prohibitive. The major systems must be designed to handle a 1:100 year event. Until recently, the City had a minimum standard of 1:25 year event, but encouraged developers to target the 1:100 year event. This standard is now used in most larger prairie cities. The difference in costs between the two targets is not significant. As well, past experience has shown it is much more cost effective to design a new development to a high standard initially. Raising the standards in an area after it has been developed is very costly.

- **Existing Development Standards** – The City has adopted a target of 1:5 year events for existing minor systems, and 1:25 year events for existing major systems. Some areas of the city do not meet these targets. In the early 1980s, a program to study the drainage problems was initiated to identify solutions and carry out remedial measures to mitigate drainage issues. A Drainage Master Plan designating 17 areas was adopted. Conditions in each area are assessed, problems identified and potential solutions proposed. Over time, work required to address the problems is carried out through the capital program.

Most of the property damage caused in Regina during intense rainstorms has been the result of basement flooding. The flooding was caused by runoff water entering the wastewater collection system, resulting in sewer overload and back up into basements. Although the drainage system is separate from the wastewater collection system, there are a number of ways stormwater can enter the wastewater collection system. These include:

- Some older buildings still have roof downspouts connected to the wastewater collection system.
- Runoff water on lots with poor grading adjacent to the building enters weeping tiles and collects in basement sump pits, which then drain into the wastewater collection system.

The City has established an objective to reduce direct connections between drainage and the wastewater collection system. An objective has also been established to reduce the runoff water entering the wastewater collection system from basement sump pits by educating homeowners about steps they can take to prevent such problems.

The most well designed system cannot function effectively unless it is properly maintained. To ensure the system functions as designed, the following objectives have been established:

- Drainage lines over 450 mm are regularly inspected and cleaned as required.
- Catch basins in areas where leaves are a problem are typically cleaned every two years and outlying areas are cleaned on a seven-year cycle.

Dykes along Wascana Creek have been constructed and flood plains are maintained to contain creek flooding. The City's objective is to prevent major damage to property and maintain public safety in the event of flood conditions. Toward that end, monitoring is carried out during spring runoff to determine the risk of flood conditions and appropriate action is taken as necessary. The City has established an objective and capital plans to upgrade dykes to meet a 1:500 flood event level, the provincial standard. The upgrading of the dykes in Riverside was completed in 2005 and those in the Dieppe area were completed in 2007.

In addition to these initiatives, in 2009, the City amended Sewer Services Bylaw No. 5601 so that weeping tile flows are prohibited from entering the wastewater system in newer neighbourhoods under development. This will reduce the likelihood of wastewater backup in newer areas in heavy rainfall events.

Drainage System Maintenance

To identify and correct problems in the drainage lines, they are cleaned and inspected on average once every seven years. In conjunction with jet cleaning some lines are inspected by a closed circuit television camera (cctv).

Jet Cleaning Program Statistics	2005	2006	2007	2008	2009
Lines Cleaned (metres) (objective 55,000 m/yr)	50,693	22,993	24,443	14,481	1,219
Average Cost (\$/metre)	1.06	1.28	1.87	1.87	2.62

Drainage system lines requiring repairs are mostly identified as a result of the inspection surveys.

Drainage System Maintenance Statistics	2005	2006	2007	2008	2009
Main Repairs (#)	2	2	6	5	2
Average Cost (\$/repair)	9,841	6,673	7,841	4,978	12,704
Manhole Repairs (#)	41	43	29	45	66
Average Cost (\$/repair)	788	932	1,039	999	1119

Since catch basins are designed to keep sand and other materials out of the drainage system, they require regular cleaning. Repairs to catch basins consist of raising or lowering the grates, replacing bricks and blocks, as well as replacing broken or missing covers. In addition, broken leads between the catch basin and the drainage lines are also replaced.

Catch Basin Statistics	2005	2006	2007	2008	2009
Catch Basin Repairs (#)	98	95	142	113	118
Average Cost (\$/repair)	574	775	585	666	998
Lead Repairs (#)	26	26	20	30	30
Average Cost (\$/repair)	2,679	2,638	3,354	4,978	3,642
Catch Basins Cleaned (#)	2,917	3,534	1,198	982	1,293
Average Cost (\$/catch basin)	31	37	32	22	75

Forecasting and Controlling Floods

Flood conditions on Wascana Creek are relatively rare. In 1996, high snowfall caused flood conditions along the creek. Creek flows were projected to be 85 cubic metres per second, or a 1:30 year flood. Although the actual peak levels were not as high as the initial predictions, it was necessary to take preventative action. Costs were incurred for labour and equipment for sandbagging and pumping water out of flooded areas, as well as repairs for some City owned structures damaged along the creek, such as the Pinkie Road Bridge. In 1999, flood control costs were incurred as a result of a large snow accumulation late in the winter, followed by a very quick spring thaw. The estimated creek flow was 40 cubic metres per second, or a 1:10 year event.

Forecasting flood conditions involves communicating with provincial agencies regarding snow volumes and predictions for spring thawing. Early in the year, Saskatchewan Watershed Authority conducts assessments of the snow cover in the Wascana Basin, as well as other areas around Saskatchewan. As the spring thaw begins, water flows are measured throughout the creek system.

Budgets are prepared assuming spring runoff levels of an average year, where no special flood control measures are required like sand bagging and pumping behind the dykes when drainage line outlets are closed. The budget covers the cost of monitoring conditions on Wascana Creek and the drainage channels, as well as putting up barricades in areas where thin ice and water levels could pose a danger to the public.

Home Flood Protection Education Program

This program informs homeowners about the causes of basement flooding and the measures they should undertake on their property to prevent flooding damage from intense summer rainstorms. The program involves media advertising, a mail out home flood protection education kit and internet page flood proofing information. Mitigation measures are required on both City and private property to accomplish neighbourhood service level improvements for managing large summer storm events and minimizing property damage and risk.

The program is concentrated between June and September during the time when most severe summer rainstorms occur and the public interest in drainage mitigation measures is greatest.

A new brochure explaining the amendments to Sewer Services Bylaw No. 5601 has been prepared and distribution of the brochure to new homeowners impacted by the changes will begin in spring 2010.

Engineering, Operations and Administration

The majority of the information regarding water, wastewater and drainage services is provided in the preceding sections of this report. The operating budget summary includes costs related to Engineering and Operations Administration.

Objectives for the planning, design, operations and maintenance engineering include:

- **Long Range Planning** – In order to meet customer demands, water, wastewater and drainage systems require high levels of capital investment. It is necessary to anticipate and plan for future requirements so that the necessary future investment can be provided. To accommodate this, the following objectives have been established:
 - Long range plans (20 to 25 years) should be carried out regularly for each of the three major Utility systems.
 - Ongoing conditions should be monitored and the long range plans updated as new information becomes available.
- **Effective Management of Capital Program** – City Administration provide planning and design engineering services for the Utility. All capital projects should be completed within their approved standards, timelines and budgets.
- **Establishment of Construction Standards** – Standards are developed for all infrastructure construction, including those relating to the Utility systems. These standards are applied to construction carried out by City crews, contractors and developers. Over time, standards evolve as new construction techniques and materials become available. The objective of these standards is to meet legislation requirements, optimize performance, and minimize the life-cycle cost for the provision of the services.
- **Customer Awareness** – There are a number of areas within the Utility operations where customer actions can collectively affect service and costs. Information is provided to customers to increase awareness. Current programs include:
 - Water Conservation
 - Cross Connection Control and Backflow Prevention
 - Home Flood Proofing
 - Creekwatch
 - Wastewater Discharge Practices

Engineering and Project Management

The Water and Sewer Services Department, the Environmental Services Department, and Development Engineering Department are responsible for planning, designing and supervising construction of the Utility systems infrastructure. A primary responsibility is overseeing the annual capital program. Projects carried out range from annual infrastructure renewal projects to less frequent major projects such as water treatment or wastewater treatment plant expansions. Engineering and design work may be done in-house or by external engineering firms. Construction work may be done by Public Works Division crews or by external contractors. The resources used for projects depend upon the nature of the project, the availability of resources, and the expertise required.

Environmental Monitoring

Environmental monitoring activities include:

- Ground water monitoring at the wastewater treatment plant.
- Surface water quality monitoring in the City's four retention lakes.
- Stormwater quality monitoring of urban drainage discharge to Wascana Creek and Wascana Lake.
- Snow dumpsite runoff monitoring.

Review of Development Proposals

Much of the City's water, wastewater and drainage systems are constructed by City staff, or by contractors under the direction of City. In the case of new development and re-development of existing areas, developers are responsible for constructing infrastructure including water, wastewater and drainage systems. This construction forms part of the Utility systems, and the City assumes responsibility for operation and maintenance of the systems.

Development proposals are reviewed by the Planning and Development Division to ensure design and construction meets City standards. Installations that do not meet City standards are identified and corrected by the developer.

Technical and Engineering Support

Public Works Division technical and engineering staff provide support to the field personnel responsible for maintaining the water, wastewater and drainage systems, and for carrying out capital construction work for projects constructed by City personnel.

In addition, staff from both Public Works Division and Planning and Development Division provides construction scheduling, construction coordination and administrative and technical construction management services, which includes:

- Establishing, monitoring, and updating construction schedules.
- Coordinating construction with Utility companies.
- Tracking and monitoring expenditures of various capital projects.
- Estimating the costs of water and sewer construction projects.
- Reviewing and analyzing unit cost information.
- Provide quality and quantity control of construction work.

Customer Billing and Collection

Initiatives for 2010

- **Utility Billing System Upgrade** – The customer information system used by the City was implemented in 1994, and had its last major upgrade in 1999. The project to upgrade the Indus Advantage CIS system was approved through the Information Systems project approval process. Since the versions of the software, operating system and database are currently unsupported, this upgrade is a very high priority for the area. This upgrade will result in a fully supported system. As part of the implementation, a number of smaller system-related initiatives are being reviewed. It is expected that a number of initiatives will no longer be required as a result of changes to the system, while others will be incorporated into the upgrade. Any system initiatives that have not been addressed through the upgrade will be reviewed and dealt with after the completion of the project.
- **Rate Review** – The current rate structure, which was set in 2007, established rates for the period 2008 – 2010. A new set of rates must be developed based on the Utility Model and anticipated capital and operating requirements going forward.
- **Reduction of Customizations** – As part of the larger Utility Billing System Upgrade, the Administration continues to review processes to ensure that customizations are eliminated. The goal is to operate within the base system as much as possible therefore ensuring a more secure system and strong data integrity.
- **Review of eBill Options for Utility Billing** – In 2010, a consultant will be engaged to review eBilling options for the Utility and bring forward recommendations for appropriate technology and implementation plans.

Status of 2009 Initiatives

- **Implementation of New Delinquency Processes** – As part of the larger Utility Billing System Upgrade, a number of changes in delinquency processing were implemented in 2009, which allow decisions to be made based on customer behaviour rather than type of customer (new, renter, owner). This new methodology provides a more consistent approach to customer service. The changes included eliminating deposits and limiting the use of tax transfers as a collection tool. In 2009, the bad debt expense was reduced from an average of 0.5% per year to approximately 0.3% of total revenue.
- **Reduction of Customizations** – As part of the Utility Billing System upgrade, processes were reviewed and changes made to eliminate customizations wherever possible.
- **Online Documentation** – In 2009, online documentation was developed for the new version of the Utility Billing System to be rolled out concurrently with the new system. The documentation will provides support to all users, and is an invaluable tool for new staff in Utility Billing. The documentation is also used to help streamline and identify processes affected by changes.

Customer Service

Service Regina provides front line customer service for the Utility as well as other City services. This priority is applied to all aspects of operations, especially in contact with external customers, but also in dealings with internal customers and in responses to questions and requests for information. Objectives for customer service include:

- Customer applications for water services and disconnections are handled accurately.
- Customers can access information about their bill and receive prompt responses to their inquiries.
- Payments can be made using convenient payment methods.
- All service requests are processed within a reasonable time frame, given the nature of the service required.

Customer call centre volumes are monitored to ensure key performance indicators (KPI) are being met. The two primary KPIs are that calls are answered within 25 seconds, 80% of the time, and that abandoned calls are kept below 5%.

Customer service is accessible by telephone, mail, fax, in-person and electronically via the City's website. Internet requests and e-business inquiries continue to increase and this continues to be an area of focus. Continued awareness of customer needs to access information and services quickly and efficiently in the manner of their choosing is the focus of customer service efforts.

Service Regina's one-stop shop approach provides customers with information about the City's services through one central contact number. By directing customer calls to the area concerned, staff ensure that the customer is dealt with effectively and efficiently at their first point of contact.

Service Regina strives to ensure customer satisfaction on every occasion in the five essential elements of service: timeliness, knowledge and competency, courtesy, fair treatment and final outcome. When all five of these elements are in place, customers rate the services provided highly. The goal of the customer service area is to ensure satisfaction in every one of these areas with every customer.

Service Regina received 197,438 calls in 2009 and answered 186,349, achieving an abandoned rate of 4%, which is a full percentage point lower than the target rate. In addition, Service Regina processed 117,320 cashier transactions, 45% of which related to the Utility.

Administration, Billing and Collection

Objectives for billing and collection include:

- Customers are billed every month.
- Customers receive accurate, timely, and informative bills.
- New payment methods are introduced where they can provide convenience to the customer, and where they are cost effective.
- Collection action is taken as required.
- Percentages of overdue accounts and uncollectible accounts are at a reasonable level.

The administration of customer accounts and the billing and collection function includes:

- Managing customer accounts, including setting up new customers, discontinuing accounts and transferring accounts from one individual to another. There is also a requirement to manage contracts with out-of-town water users who receive water from the City.
- Managing activities related to water meters includes obtaining meter readings and handling turn ons or turn offs of water service. Customers are divided into automated meter-reading routes so the meters are read according to a monthly schedule.
- Water services must be connected and disconnected in response to customer requests and as a result of collection efforts. The following table provides information on the number and reasons for turn offs and turn ons.

Turn On/Turn Off Statistics	2005	2006	2007	2008	2009
Daytime Turn Ons (#)	2,076	2,076	2,021	1,520	1,594
Daytime Turn Offs (#)	2,270	2,270	2,266	1,882	2,063
Turn Offs Due to Arrears (#)	1,109	1,109	1,171	1,283	1,553
Total	5,455	5,455	5,458	4,685	5,210

- Generating customer bills – Customers are divided into billing cycles so each customer is billed every month.
- Collection efforts take many forms. Interest is added to outstanding balances, which encourages timely payment. When accounts remain outstanding, payment arrangements are negotiated where possible. This includes maintaining a post-dated cheque database, as well as providing equalized payment options for Utility accounts. The following table provides a summary of the Utility accounts outstanding as at December 31, 2009.

Analysis of Receivables	Utility Accounts Receivable			
	December 31, 2008		December 31, 2009	
	Amount Outstanding (\$)	Per Cent of Total (%)	Amount Outstanding (\$)	Per Cent of Total (%)
0-30 Days	3,119,302	78.0	4,356,254	87.1
31-90 Days	388,206	9.7	246,565	4.9
91-150 Days	162,147	4.1	49,463	1.0
151-365	113,886	2.8	123,428	2.5
>365 Days	215,658	5.4	228,255	4.6
Total	3,999,199	100	5,003,966	100

Collection efforts are not always successful. Provincial legislation provides the authority to enforce payment. There are a variety of options available which include: discontinuing Utility service, transferring outstanding Utility balances to the tax roll if the account is with the property owners or placing the account with an external collection agency.

Effective in the 2nd quarter of 2009, new delinquency processes were implemented. The new processes allow decisions to be made based on customer behavior rather than type of customer (new, renter, owner) providing a more consistent approach to customer service. As part of this process, more aggressive collection timelines were also implemented for delinquency accounts instead of transferring outstanding balances to taxes. The first approach to collecting outstanding balance is now to disconnect the Utility service if the customer does not respond to collection notices.

Policies are being developed for the application of security deposits and tax transfer as a collection tools; they are no longer the first option for collection of outstanding balances.

With the implementation of the new delinquency processes, the number of mailed notices has been reduced and more effort has been put into addressing accounts before they become a significant problem. Payment arrangements are made available to allow customers more time to pay when necessary.

If a customer with an account from an old address moves to a new address, the City requires payment or acceptable payment arrangements immediately. For those accounts where the customer does not move to a new location with an account, the success rate for collection is greatly reduced. Also, these accounts do not have a high rate of success when placed with a collection agency.

Debt Costs

This program includes the cost of principal and interest for debt issued to finance Utility capital projects, along with the cost of the debt issue. Debt charges are made up of two elements:

- Interest – This is the cost of interest payments on all outstanding serial debentures.
- Principal repayments – These payments represent the cost to redeem the principal portion of a serial debenture that matures each year. A serial debenture does not remain outstanding in full for the life of the debt issued. As with a mortgage, a portion of the principal amount of the debt matures and is paid each year until the debt is fully mature.

The following table shows the existing annual debt charges and debt maturities.

Schedule of Debt Charges and Debt Maturities (\$000's)

Year	Annual Debt Charges (\$)	Debt Maturities		
		Debt Maturing (\$)	Per Cent of Total (%)	Cumulative Percentage Reduction (%)
2010	8,405.5	5,506	8.8	8.8
2011	8,154.0	5,506	8.8	17.6
2012	7,888.7	5,506	8.8	26.4
2013	3,615.6	1,506	2.4	28.8
2014	46,652.8	44,606	71.2	100.0
	Total	62,630	100.0	

In 2010, debt in the amount of \$42.4 million will be reassigned from the GTH to fund the General Utility Reserve. As a result of the reassignment of this debt, no additional debt is required in 2010 to fund the Utility's capital program. Additional debt will be required for the remainder of the 2010 – 2014 Utility Capital Program in the amount of \$22.6 million in 2011, \$52 million in 2012, and \$45.5 million in 2013. In 2014, the GTH debt will mature and new debt of \$30 million will be required to replace it. The Utility Model includes funding for debt issuance costs and the repayment of projected debt issues based on a twenty-year term and an interest rate of 6%.

For further details on debt projections for future years, see Utility Capital Funding Section.

Utility Capital Program

Capital Program Summary

	2010	2011	2012	2013	2014	Total
Capital Expenditures (\$000's)						
Water Supply, Pumping & Distribution	15,524	14,294	14,107	9,944	9,924	63,793
Wastewater Collection & Treatment	34,065	29,990	57,790	55,890	7,490	185,225
Drainage	12,505	5,430	6,150	5,920	3,550	33,555
Total Expenditures	62,094	49,714	78,047	71,754	20,964	282,573
Capital Funding (\$000's)						
General Utility Reserve	41,872	17,195	8,906	16,193	18,323	102,489
Service Agreement Fees - Utility	16,245	9,285	15,500	8,460	1,000	50,490
Debt	-	22,550	52,000	45,460	-	120,010
Other External Contributions	3,977	684	1,641	1,641	1,641	9,584
Total Funding	62,094	49,714	78,047	71,754	20,964	282,573

Infrastructure Overview

Regina has a substantial investment in utility infrastructure. A challenge for Regina, and other cities, is to generate sufficient funds to maintain these assets. The gap between the annual requirement to sustain the infrastructure and the annual investment is referred to as the "Infrastructure Gap". Regina is a relatively young city and has to some extent been shielded from the full impact of its utility infrastructure deficit since, until recently, much of the buried infrastructure was still within its expected service life.

In recent years, there has been increased discussion of the infrastructure deficit faced by cities, and the need for additional funding from the senior governments and/or alternate revenue sources for cities. In 2009, the Federal Government established the Federal Infrastructure Stimulus Fund, which provides funding towards the rehabilitation or construction of provincial, territorial, municipal and community infrastructure projects. The City has applied for \$3,133,000 in funding for 2010 under this program.

In addition, the City has applied for funding under the Federal Green Infrastructure Fund to be used for the Wastewater Treatment Plant Expansion project.

In 2004, City Council approved the Residential Growth Study (Report CR04-196). Implementation of the Residential Growth Study will require integration of infrastructure requirements into sector and concept plans. These plans will detail the physical and engineering aspects of the new infrastructure along with funding and phasing of the work. Current development policies are based on the provision of trunk services uniformly throughout the city, with Servicing Agreement Fees, levied pursuant to *The Planning and Development Act, 2007*, the same for all newly developed land, irrespective of location. The development scenarios adopted in the Residential Growth Study result in significant trunk infrastructure requirements and costs for each of the growth areas.

Section 22.4 of *The Cities Regulations* requires Council to adopt a capital investment strategy that includes the method used for determining capital plans respecting the waterworks. Capital requirements (capital investment strategy) are determined based on engineering and planning studies that take into account the infrastructure requirements of the Utility required to meet the service goals of the Utility, as

determined by City Council or prescribed by legislation. Infrastructure requirements are being addressed through a series of studies. Studies recently completed or underway include:

- The Wastewater Collection System Assessment Study, completed in 2004, estimated the replacement value of wastewater collection system as \$635 million. The study defined requirements for the long-term sustainability of the wastewater collection infrastructure. In 2006, further work was done to investigate inflow and infiltration to the wastewater collection system.
- The review of the Long Term Water Utility Plan was completed in 2006. It examines the present condition of Regina's water system, forecasts the requirements for the next 20 years and provides a plan for meeting future requirements. An estimate of the replacement value for the water distribution system is \$250 to \$300 million, with a further \$350 to \$400 million for the supply system, including the City's share of the Buffalo Pound Water Treatment Plant.
- In 2007, the City of Regina partnered with the City of Saskatoon, for the development of a Buried Asset Repair Strategy. Approximately two-thirds of the water distribution and wastewater collection systems were constructed in a thirty-year period between the early 1950s and the late 1970s. In this period, almost all of the water distribution system construction used asbestos cement (ac) pipe. AC pipe has a reliable service life, under the conditions that prevail in Regina, of 50 years. In recent years, there has been an increasing frequency in breaks in asbestos cement pipe. This pattern will likely continue as the system ages.
- The value and infrastructure requirements of the sewage treatment plant were documented through the Sewage Treatment Planning Study. The final report was completed in late 2005. The initial Wascana Creek Receiving Environment Study was also completed in 2005. Both studies were used in developing capital plans for the wastewater treatment plant upgrade and to develop future plans to create a receiving environment water quality model.
- In 2010, the City of Regina will complete the pre-design study for the Wastewater Treatment Plant Expansion Project. This project is required to meet new regulatory requirements as well as provide expanded hydraulic and process capability associated with future City growth.

These studies will contribute to determining the infrastructure gap.

Water Supply, Pumping and Distribution

Capital Summary (\$000's)	2010	2011	2012	2013	2014
Capital Expenditures					
1. Water Supply					
- Supply Line Improvements	200	1,000	1,000	-	-
- Buffalo Pound Water Treatment Plant Upgrade	650	2,500	6,000	6,000	6,000
- Albert Street Reservoir Roof Repair	2,500	-	-	-	-
2. Water Pumping					
- System Upgrades for Pressure Zone 2	6,700	6,500	-	-	-
- Water Pumping Station Upgrades	1,170	400	200	200	200
3 Water Distribution					
- Water infrastructure Renewal	1,500	1,800	2,000	2,000	2,000
- Second Pressure Zone Implementation	-	300	2,600	-	-
- Trunk Watermain - Arcola Ave	110	-	-	-	-
- Trunk Watermain - Pasqua Street	330	-	-	-	-
- Trunk Watermain - Rochdale Blvd	-	70	300	-	-
- Water Distribution System Equipment	410	-	-	-	-
- Watermain Deadend Connection	-	100	100	100	100
- Hydrant Replacement	250	150	150	150	150
- Water Service Line Replacement	1,250	1,250	1,250	1,250	1,250
4 Other Capital Projects					
- Trench Settlement Remediation	200	200	200	200	200
- AMR System Equipment Replacement Upgrade	-	20	20	40	20
- Utility Billing system Upgrade	100	-	-	-	-
- Bulk Water Loading Station	150	-	-	-	-
- Automated Electronic Defibrillators	4	4	4	4	4
- Trunked Radio System User Gear Replacement	-	-	283	-	-
Total Expenditures	15,524	14,294	14,107	9,944	9,924
Capital Funding					
General Utility Reserve	10,149	1,715	1,707	3,944	8,283
Service Agreement Fees - Utility	5,197	4,985	2,900	-	-
Debt	-	6,910	7,859	4,359	-
Federal Capital Grants	178	684	1,641	1,641	1,641
Total Funding	15,524	14,294	14,107	9,944	9,924

Water Supply

Funding will cover consulting, contractors, property, materials and any other work, resources, staff, technologies or support related to each of the projects described below.

- **Supply Line Improvements** – This program inspects, repairs, and replaces main valves, valve structures and other miscellaneous work on the Buffalo Pound supply pipeline and other major supply mains within the City. As the pipelines age, improvements are necessary to ensure the reliability of the water supply to the City and reduce the number of emergency repairs. The 2010 budgeted amount of \$200,000 will be funded from the City's General Utility Reserve.
- **Buffalo Pound Water Treatment Plant Upgrades** – Improvements are required at the Buffalo Pound Water Treatment Plant to continue meeting quantity and quality of treated water delivered to Regina and Moose Jaw. Work includes design studies, detailed design engineering, and several

installation construction contracts over a multiple year upgrade schedule. Funding is provided by the City's General Utility Reserve (73%) and the City of Moose Jaw (27%). In 2010, \$472,225 is funded by the City of Regina, and \$177,775 by the City of Moose Jaw.

- **Albert Street Reservoir Roof Repair** – The Albert Street Water Reservoir roof requires repairs. This program will repair the roof in order to extend the life of the reservoir roof. The 2010 budgeted amount of \$2,500,000 will be funded from the City's General Utility Reserve.

Water Pumping

Funding will cover consulting, contractors, property, materials and any other work, resources, staff, technologies or support related to each of the projects described below.

- **System Upgrades for Pressure Zone 2** – An engineering analysis indicated upgrades to the water system would be necessary to improve pressure and fire flows to the north portion of the City. This project will ensure adequate service to existing and new developments. To provide flexibility to manage future anticipated debt levels within the Utility, Administration will consult with the development community, assess the impacts and provide recommendations to City Council to proceed with or defer the timing of the construction on this project to future years. The funding for this project is split with 29% of the funding from the City's General Utility Reserve and 71% from Utility Servicing Agreement Fees. In 2010, \$1,943,000 is funded from the General Utility Reserve and \$4,757,000 from Utility Servicing Agreement Fees.
- **Water Pumping Stations Upgrades** – This project provides for the replacement of equipment and components in water pumping stations which have reached the end of their service life or cannot be economically repaired. It is funded from the City's General Utility Reserve, with \$1,170,000 requested for 2010.

Water Distribution

Funding will cover consulting, contractors, property, materials and any other work, resources, staff, technologies or support related to each of the projects described below.

- **Water Infrastructure Renewal** – The water distribution system requires ongoing rehabilitation and upgrading to maintain and improve the level of service and ensure the system's reliability and safety. The program typically includes inspection, replacement and rehabilitation of water distribution mains and appurtenances. The 2010 budgeted amount of \$1,500,000 will be funded from the City's General Utility Reserve.
- **Second Pressure Zone Implementation** – A pool of funds set aside to implement the distribution infrastructure related to the second pressure zone to support development in the northeast and northwest sectors. This project is funded from Servicing Agreement Fees and will begin in 2011.
- **New Trunk Watermains**
 - **Arcola Avenue to 250 m N** – This project provides for the installation of approximately 250 m of 400 mm diameter trunk water main to service the Greens on Gardner. \$110,000 is requested in 2010.
 - **Pasqua Street from Junor Drive to Diefenbaker Drive** – This project provides for the installation of approximately 400 m of 400 mm diameter trunk water main along Pasqua Street. \$330,000 is requested in 2010.

- **Rochdale Blvd from Wal-Mart to 600 m West** – This project provides for the installation of approximately 600 m of 400 mm diameter trunk water main along Rochdale Boulevard. This project will begin in 2011.

All of these projects are funded from Servicing Agreement Fees.

- **Water Distribution System Equipment Purchase** – This project will fund a Hydroexcavation Unit required for repairs to curb boxes and rods, and main valve boxes. The service is currently being provided by a contractor. In addition, it will provide a valve exercising unit required to mechanize the exercising of main valves. The 2010 budgeted amount of \$410,000 will be funded from the City's General Utility Reserve.
- **Watermain Dead-End Connections** – This program improves the water distribution system by eliminating dead-ends and/or installing flush outs. The City's General Utility Reserve funds this program. There is no funding requirement for this program in 2010.
- **Hydrant Replacement** – This program replaces old fire hydrants at locations where streets and sidewalks are being replaced or when a hydrant can no longer be repaired. The 2010 budgeted amount of \$250,000 will be funded from the City's General Utility Reserve.
- **Water Service Line Replacement** – The polybutylene service lines installed in the City are subject to failure. The high cost of emergency repair can be significantly reduced by replacing the connections. The 2010 budgeted amount of \$1,250,000 will be funded from the City's General Utility Reserve.

Other Capital Projects

Funding will cover consulting, contractors, property, materials and any other work, resources, staff, technologies or support related to each of the projects described below.

- **Trench Settlement Remediation** – Cracking and settling of sidewalks, curbs, gutter and pavement occur as a result of backfill settlement at watermain work locations, resulting in drainage problems. This program corrects settlement at these locations. The 2010 budgeted amount of \$200,000 will be funded from the City's General Utility Reserve.
- **AMR System Equipment Replacement Program** – In order to obtain readings from AMR meters, the City has deployed a number of hand-held and vehicle-mounted (VXU) radio-read devices. These devices are warranted and can be repaired and upgraded for a period of time, but upgrades to the technology and necessary replacements due to damaged equipment require the implementation of a replacement program for these devices. This program is funded from the City's General Utility Reserve and does not require funding in 2010.
- **Utility Billing System Upgrade** – The upgraded version of the Utility Billing system has significant new functionality, including e-billing, electronic work queue, customer contact tracking, and dispatch functionality. This funding will provide additional resources to test and implement additional functionality based on priorities identified through the business planning process. The 2010 budgeted amount of \$100,000 will be funded from the City's General Utility Reserve.
- **Bulk Water Loading Station** – A new Bulk Water Loading facility is required to replace the existing facility. Benefits include reduced risk of backflow and water contamination, elimination of traffic congestion, and improved security at the Public Works Yard. The 2010 budgeted amount of \$150,000 will be funded from the City's General Utility Reserve.

- **Automated Electronic Defibrillators** – This project is to purchase Automated External Defibrillators for all buildings used for provision of utility services. The 2010 budgeted amount of \$4,000 will be funded from the City's General Utility Reserve.
- **Trunked Radio System User Gear Replacement** – Trunked Radio System Infrastructure Upgrade will require new user gear (portable and mobile radios) as existing gear will not work on the new infrastructure. This program is funded from the City's General Utility Reserve and does not require funding in 2010.

Wastewater Collection and Treatment

Capital Summary (\$000's)	2010	2011	2012	2013	2014
Capital Expenditures					
1. Wastewater Collection:					
- Trunk Main Upgrading	1,100	1,100	1,100	1,100	1,100
- Southeast Sector Serviceability Study	300	-	-	-	-
- Westhill Wastewater Collection system Study and Improvements	50	500	-	-	-
- Wastewater Trunk Main	-	200	1,150	-	-
- Lift Station Upgrade	450	400	400	400	-
- Wastewater System Upgrades and Replacement	1,000	1,000	1,000	1,000	1,000
- Wastewater Infrastructure Renewal	3,750	4,000	4,250	4,500	5,000
2. Wastewater Treatment:					
- Wastewater Treatment Plant Expansion	5,750	15,000	45,000	44,000	-
- Wastewater Treatment Centre of Excellence	2,000	-	-	-	-
- Wastewater Treatment Plant Improvements	5,000	3,500	1,600	4,500	-
- Wastewater Treatment Plant Refurbishing	1,565	290	290	390	390
- McCarthy Boulevard Pumping Station Upgrade	10,000	4,000	3,000	-	-
- Upgrade Force mains-McCarthy Pump Station to WWTP	1,000	-	-	-	-
- Asset Management	100	-	-	-	-
- Waste Hauler Station Development	2,000	-	-	-	-
Total Expenditures	34,065	29,990	57,790	55,890	7,490
Capital Funding					
General Utility Reserve	27,153	10,300	7,199	6,329	7,490
Service Agreement Fees - Utility	3,113	4,050	9,700	8,460	-
Federal Capital Grants	3,799	-	-	-	-
Debt	-	15,640	40,891	41,101	-
Total Funding	34,065	29,990	57,790	55,890	7,490

Wastewater Collection

Funding will cover consulting, contractors, property, materials and any other work, resources, staff, technologies or support related to each of the projects described below.

- **Trunk Main Upgrading** – The wastewater trunk system requires upgrading and refurbishing on an ongoing basis. Upgrades may include inspection, assessment, relining, replacement, and upgrades. This rehabilitation restores the level of service and ensures the reliability of the system. The 2010 budgeted amount of \$1,100,000 will be funded from the City's General Utility Reserve.
- **Southeast Sector Serviceability Study** – This study will determine the water, wastewater, and drainage serviceability of the southeast sector under the 300,000 population scenario. The study will be funded from Servicing Agreement Fees, with \$300,000 requested in 2010.
- **Westhill Wastewater Collection System Study and Improvements** – The Northwest Sector Serviceability Study (NWSSS)(AECOM 2008) identified the Westhill area as having reduced service levels and capacity constraints within the wastewater system which could impact future development and indicated that further study was required. Subsequently, the City conducted a review and

determined that not only are there potential capacity constraints but also that significant information gaps exist which make an accurate assessment difficult. A more thorough assessment of the wastewater system in the area, including the operation of the pumping station, is required. The study will focus on quantifying the existing system capacities and constraints, and identifying solutions that not only support development but increase the overall level of service. The study is funded from Utility Servicing Agreement Fees, with \$50,000 requested in 2010.

- **Wastewater Trunk Main Rochdale Boulevard from Wal-Mart to Kensington Greens** – This project provides for the installation of approximately 1400 m of 600 mm sanitary trunk along Rochdale Boulevard. Funding is from Utility Service Agreement Fees. This project will begin in 2011.
- **Lift Station Upgrade** – The City's wastewater lift stations are aging and require upgrading to restore or improve the level of service and to reduce emergency repair costs. This program will include assessment, pre-design, rehabilitation, upgrades and/or replacement of existing lift stations. The City's General Utility Reserve funds this program, with \$450,000 requested in 2010.
- **Wastewater System Upgrades and Replacement** – This program replaces and/or upgrades sewer mains and related infrastructure. Renewal may include assessment, modelling, correction of recirculation and cross connection locations. The City's General Utility Reserve funds this program, with \$1,000,000 requested in 2010.
- **Wastewater Infrastructure Renewal** – The wastewater collection system requires ongoing rehabilitation and upgrading to maintain and improve the level of service and to ensure the systems reliability. This program includes inspections, assessments, relining, replacement, and rehabilitation. The rehabilitation is typically done in conjunction with scheduled roadway renewal projects. The City's General Utility Reserve funds this program, with \$3,750,000 requested in 2010.

Wastewater Treatment

Funding will cover consulting, contractors, property, materials and any other work, resources, staff, technologies or support related to each of the projects described below.

- **Wastewater Treatment Plant Expansion** – In order to meet new regulatory requirements of both the Provincial and Federal Governments, a major upgrade of the Wastewater Treatment Plant is required to treat the City's wastewater to higher standards. Work involves design engineering, equipment procurement, and installation construction contracts over a multiple year project schedule. An application has been submitted for \$1 million in funding through the Federal Infrastructure Stimulus Fund Program for 2010. An application has also been submitted to the Federal Green Fund. Utility Servicing Agreement Fees will provide 18% of the overall funding for this project. Any additional funding required in 2010 will be provided from the General Utility Reserve and from Debt in 2011, 2012, and 2013. In 2010, \$3,715,000 is requested from the General Utility Reserve, with \$1,035,000 funded from Utility Servicing Agreement fees, along with the requested \$1,000,000 in funding from the Federal Infrastructure Stimulus Fund Program.
- **Wastewater Treatment Centre of Excellence** – Develop a Centre of Excellence focused on environmental monitoring and modelling of chemicals in the wastewater and receiving environments. Funding for this project has been submitted to the Federal Green Fund. This project will proceed only if external funding is received and federal funding is obtained for the expansion as well. \$1,334,000 is requested from the General Utility Reserve, with \$666,000 requested from the Federal Infrastructure Stimulus Fund Program.
- **Wastewater Treatment Plant Improvements** – The Wastewater Treatment Plant requires improvements to the grit removal system, sludge handling system, a new fire water protection system, and addition of a maintenance shop. In 2010, \$228,000 in funding is provided from Utility

Servicing Agreement Fees, with the remaining \$4,772,000 requested from the General Utility Reserve. Additional funding is provided from Utility Servicing Agreement Fees in 2011 (\$450,000) and 2013 (\$540,000), with all other funding provided from debt.

- **Wastewater Treatment Plant Refurbishing** – This project provides funding for major maintenance projects beyond regular operating and maintenance budget works to refurbish various areas of the Wastewater Treatment Plant, including administration, laboratory, lagoons, primary treatment plant, tertiary treatment plant, and the site. The City's General Utility Reserve funds this program, with \$1,565,000 requested in 2010.
- **McCarthy Boulevard Pumping Station Upgrade** – McCarthy Boulevard Pumping Station requires upgrades involving pumping, screens for removal of solids and debris, and HVAC/electrical components to continue to provide reliable wastewater conveyance to the Wastewater Treatment Plant. An application has been submitted for \$2.133 million in funding through the Federal Infrastructure Stimulus Program for 2010. Utility Servicing Agreement Fees will provide \$1.5 million in funding in 2010, \$600,000 in 2011, and \$450,000 in 2012, with all additional funding provided from the General Utility Reserve. In 2010, \$6,366,667 is requested from the General Utility Reserve.
- **Upgrade Forcemain McCarthy to WWTP** – Upgrades to the wastewater system forcemains between McCarthy Boulevard Pump Station and the Wastewater Treatment Plant are required. Funding is provided from the General Utility Reserve, with \$1,000,000 requested in 2010.
- **Asset Management** – As part of the Infrastructure Management Strategy, software will be evaluated and purchased for the purpose of Asset Management. This project will be funded from the General Utility Reserve, with \$100,000 requested in 2010.
- **Waste Hauler Station Development** – This project involves the development of a new user pay wastewater truck hauler discharge station to serve city and local area needs. Currently, truck haulers discharge at the McCarthy Boulevard Pump Station (MBPS); however, impacts of traffic, noise, odour as well as incompatibility with the main MBPS upgrade require a new hauler station at an alternate location. Funding is from the General Utility Reserve, with \$2,000,000 requested in 2010.

Drainage

Capital Summary (\$000's)	2010	2011	2012	2013	2014
Capital Expenditures					
1. Drainage Systems:					
- The Creeks Sedimentation Pond	660	-	-	-	-
- Dorothy Street Crossing Upgrade	200	1,430	-	-	-
- Ditch Realignment Armour Rd to McCarthy Blvd	300	-	-	-	-
- Rehabilitate Ditch-McCarthy Blvd Culvert Crossing to CNR	250	-	-	-	-
- Highland Park/Cityview (Area 13A)	300	-	-	-	300
- Various Detention Ponds	750	50	900	-	300
- Chuka Creek Channelization-Phase 1	575	-	-	-	-
- Chuka Creek Channelization-Phase 2	-	200	2,000	-	-
- Detention Pond & Storm Trunk to Chuka Creek	3,700	-	-	-	-
- South West Quadrant Detention (Victoria Avenue Interchange)	1,320	-	-	-	-
- South East Quadrant Detention (Victoria Avenue Interchange)	-	-	-	3,670	-
- Harbour Landing Inverted Siphon	1,700	-	-	-	-
- Harbour Landing Detention Ponds	-	-	-	-	700
- Catch Basin Installations	50	50	50	50	50
- Drainage Pumping Station Upgrading	300	1,500	1,000	-	-
- Drainage Infrastructure Renewal	2,000	2,000	2,000	2,000	2,000
- Dykes, Drainage Channels Lake Improvements	400	200	200	200	200
Total Expenditures	12,505	5,430	6,150	5,920	3,550
Capital Funding					
General Utility Reserve	4,570	5,180	-	5,920	2,550
Service Agreement Fees - Utility	7,935	250	2,900	-	1,000
Debt	-	-	3,250	-	-
Total Funding	12,505	5,430	6,150	5,920	3,550

Drainage

Funding will cover consulting, contractors, property, materials and any other work, resources, staff, technologies or support related to each of the projects described below.

- **The Creeks Sedimentation Pond** – This project will fund the construction of a sedimentation pond for Creeks subdivision. Funding for this project is from Utility Servicing Agreement Fees, with \$660,000 requested in 2010.
- **Dorothy Street Crossing Upgrade** – The Dorothy Street Crossing of the North Storm Channel will be upgraded in order to ensure the reliability of the storm infrastructure and to protect the downstream end of the channel. The project may consist of upgrading the culverts, improving erosion control, and increasing the capacity. The City's General Utility Reserve funds this program, with \$200,000 requested in 2010.

- **Ditch Realignment - Armour Road to McCarthy Boulevard** – This project provides for the design and construction of drainage ditch realignment from Armour Road/Diefenbaker Drive to McCarthy Boulevard for Lakeridge Addition. Funding for this project is from Utility Servicing Agreement Fees with \$300,000 requested in 2010.
- **Rehabilitate Ditch from McCarthy Boulevard Culvert Crossing to CNR Crossing** – This project will provide for the rehabilitation of the ditch from McCarthy Boulevard to CNR crossing for development of the area north of Lakewood, known as Skyview. Funding for this project is from Utility Servicing Agreement Fees with \$250,000 requested in 2010.
- **Highland Park/Cityview (Area 13A)** – This program will upgrade the drainage system in Highland Park to improve the desired drainage level of service in the area. The City's General Utility Reserve funds this program with \$300,000 requested in 2010.
- **Various Detention Ponds**
 - **Detention pond (E) - Pasqua Street and South of Rochdale Boulevard** – Funding of \$50,000 in 2011 and \$550,000 in 2012 is required for a detention pond to be located east of Pasqua and south of Rochdale Blvd. Excavation, outlet pipe and coarse grass seeding involved
 - **Detention pond (F) – Pasqua Street at Rochdale Boulevard** - In 2014, \$300,000 is required for a new detention pond east of Pasqua Street and north of Rochdale to serve newly developed area of Argyle Park North, in the Northwest of the city.
 - **Detention pond (H) – McCarthy Boulevard at Rousseau Crescent** – In 2010, \$750,000 is required for a new detention pond to serve the newly developed area of Lakeridge Addition, in the Northwest of the city.
 - **Detention pond (J) – CNR Railway north of Hird Crescent** – In 2012, \$350,000 is required for a new detention pond east of CNR railway and north of Hird Crescent to serve the newly developed area Lakeridge Addition, in the Northwest of the city.

Funding for these detention ponds is from Utility Servicing Agreement Fees.

- **Chuka Creek Channelization – Phase 1** – Channelization of Chuka Creek adjacent to The Creeks is required for the management of storm water in the developments of The Greens on Gardner and The Creeks. This project is funded from Utility Servicing Agreement Fees with \$575,000 requested in 2010.
- **Chuka Creek Channelization – Phase 2** – This project will complete the channelization of Chuka Creek adjacent to The Greens on Gardiner Subdivision. Funding is from Utility Servicing Agreement Fees. No funds are requested for 2010.
- **Detention Pond and trunk sewer to Chuka Creek** – Construction of a detention pond and installation of a storm trunk, which outlets to Chuka Creek, is required for the management of storm water in the development of the Greens on Gardiner Subdivision. This project is funded from Utility Servicing Agreement Fees with \$3,700,000 requested in 2010.
- **South West Quadrant Detention (Victoria Avenue Interchange)** – This project will improve the drainage system in the area near the Victoria Avenue and Highway #1 interchange. Upgrading the detention in the SW Quadrant of the interchange will improve the desired drainage level of service in the Glen Elm and Glencairn area. This is the second part of the three Glencairn Stormwater Management Projects. The City's General Utility Reserve funds this program with \$1,320,000 requested in 2010.
- **South East Quadrant Detention (Victoria Avenue Interchange)** – This is the final part of the three part Glencairn Stormwater Management Improvement Projects. Upgrading the detention of the SE Quadrant in the Victoria Avenue and Highway #1 Interchange will improve the drainage level of

service in the underpass. The City's General Utility Reserve funds this program. No funds are requested in 2010.

- **Harbour Landing Inverted Siphon and James Hill Road Crossing** – An inverted siphon under the TransCanada Pipeline right-of-way is required as part of the development of the Harbour Landing Subdivision. This project is funded from Servicing Agreement Fees with \$1,700,000 requested in 2010.
- **Harbour Landing Detention Ponds**
 - **Harbour Landing Detention Pond - MR8** – In 2014, \$200,000 is required for excavation, coarse grass seeding, and outlet structure from the detention pond to the storm channel.
 - **Harbour Landing Detention Pond – MR9** – In 2014, \$200,000 is required for excavation, coarse grass seeding, and outlet structure from the detention pond to the storm channel.
 - **Harbour Landing Detention Pond – MR10** – In 2014, \$300,000 is required for excavation, coarse grass seeding, and outlet structure from detention pond to storm channel.
 - **Harbour Landing Detention Pond – MR11** – In 2010, capital carry-forward from 2009 will be used to fund excavation coarse grass seeding, and outlet structure from detention pond to storm channel for this project.
 - **Harbour Landing Detention Pond – MR12** – In 2010, capital carry-forward will be used for excavation, coarse grass seeding, and outlet structure from detention pond to storm channel.Funding for these detention ponds is from Utility Servicing Agreement Fees.
- **Catch Basin Installations** – This program installs catch basins at various locations where severe ponding is a problem. The City's General Utility Reserve funds this program with \$50,000 requested in 2010.
- **Drainage Pumping Station Upgrading** – This is phase three of the upgrades required to improve the Ring Road Lift Station. This project improved the level of service of the drainage management system at the CNR overpass. Access to the Lift Station is also improved to allow for proper maintenance. The City's General Utility Reserve funds this program with \$300,000 requested in 2010.
- **Drainage Infrastructure Renewal** – The drainage system requires ongoing rehabilitation and upgrading to maintain and improve the level of service and to ensure the systems reliability. This program includes inspections, assessments, relining, replacement, and rehabilitation. The rehabilitation is typically done in conjunction with scheduled roadway renewal projects. The City's General Utility Reserve funds this program with \$2,000,000 requested in 2010.
- **Dykes, Drainage Channels, Lake Improvements** – This program rehabilitates and improves the level of service of stormwater management facilities such as dykes, channels and ponds. Periodic assessments, repairs, modifications and improvements are required to ensure the integrity and capacity of these systems. The City's General Utility Reserve funds this program with \$400,000 requested in 2010.

Utility Capital Funding

Funding for the Water and Sewer Utility Capital Program is primarily from the following sources:

- General Utility Reserve.
- Utility Servicing Agreement Fees.
- Federal and Provincial Infrastructure Programs.
- Debt.

General Utility Reserve

The General Utility Reserve is funded through the operating surplus of the Utility. Each year the Utility generates a surplus, a portion of which is transferred to the general operating and capital budgets, with the balance transferred to the General Utility Reserve. The reserve is primarily used to fund capital projects, but is available should there be an operating shortfall. The following table provides a projection for the General Utility Reserve.

	<u>General Utility Reserve (\$000's)</u>				
	2010	2011	2012	2013	2014
Reserve Balance - Start of Year	12,151	34,115	39,651	50,617	54,100
Net Operating Surplus	21,436	24,753	26,283	29,653	(13,280)
Transfer of GTH Debt	42,400	-	-	-	-
Capital Program Requirement ⁽¹⁾	(41,872)	(19,217)	(15,317)	(26,170)	(22,390)
Reserve Balance - End of Year	34,115	39,651	50,617	54,100	18,430

Note:

1. *The Capital Program Requirement reflects an estimated inflation rate applied to capital requirements. The 2010 – 2014 Utility Capital Program is presented in current dollars (without inflation). The Utility model incorporates projected increases in revenues and expenditures due to inflation. The net operating surplus reflects future projected increases and as such, the inflationary projection for capital program requirements is also used in this table.*

Servicing Agreement Fees

Servicing Agreement Fees (SAF) are pursuant to *The Planning and Development Act, 2007* and are collected when a servicing agreement is entered into between the City and a developer. The agreements require a payment to the City of a predetermined amount per hectare of land within the development area. The funds are intended to be used towards the construction of infrastructure to support new development.

In the case of roadways, water, and sewer costs for development, the City would normally incur the costs prior to the full development of an area. In other words, the costs are front ended through City funding and paid back over time through collection of servicing fees. Parks and recreation infrastructure costs are generally incurred later in the process.

For 2010, the Utility Servicing Agreement Fees are set at \$107,114 per hectare of land within the development area. The payment schedule requires 30% upon execution of a servicing agreement,

another 40% within nine months and the balance within a further nine months. Eligibility of funding is by policy of City Council and includes:

- 100% of funding for the cost of trunk water mains larger than 250 mm in diameter with no service connections permitted.
- A portion of the cost to construct water mains larger than 250 mm in diameter.
- 100% of funding for wastewater collection trunks which are 300 mm or greater in diameter with no service connections permitted.
- A portion of the cost to construct wastewater collection mains larger than 300 mm in diameter.
- 100% of funding for wastewater pump or lift stations that are a component of a regional servicing plan.
- Population-based funding for expansion to the wastewater treatment plant for capacity for new development.
- 100% of the funding for water, wastewater or drainage studies providing for the servicing of new land development.
- 100% of funding for drainage trunks 1350 mm or greater in diameter with no service connections permitted.
- A portion of the cost to construct drainage mains larger than 1350 mm in diameter.
- 100% of funding for drainage lift stations that are an approved component of a regional drainage plan.
- 100% of funding for a dry bottom detention facility (or the equivalent for a dry facility if a wet retention pond is constructed) if the pond is an approved component of a regional drainage plan.
- 100% of funding for new or upgraded storm channels or drainage ways that are an approved component of a regional drainage plan.

Revenue from Servicing Agreement Fees is recognized when the funds are spent on an eligible project. Historically, capital projects eligible for Servicing Agreement Fees funding have been undertaken ahead of the funds being available resulting in a shortfall in Servicing Agreement Fees funding. The projections have been based on information provided by the development community, and estimates from Development Engineering for 2010 to 2014.

Servicing Agreement Fees (\$000's)

	2010	2011	2012	2013	2014
Balance - Start of Year	(35,451)	(45,254)	(48,292)	(57,890)	(60,375)
Servicing Agreement Fees ⁽¹⁾	8,569	9,426	10,389	10,784	11,215
Interest applied to negative balance ⁽²⁾	(2,127)	(2,715)	(2,898)	(3,475)	(3,624)
Capital Program Requirements ⁽¹⁾	(16,245)	(9,749)	(17,089)	(9,794)	(1,204)
Balance - End of Year	(45,254)	(48,292)	(57,890)	(60,375)	(53,988)

Note

1. The projected Servicing Agreement Fees incorporate the approved rates for 2009, and increases in future years for inflation. The capital program requirements also incorporate projected increases due to inflation.
2. If the Servicing Agreement Fee Reserve is in a negative position, interest is calculated at the rate paid by the City for any debt required to fund the negative balance.

A review of the SAF Policy in 2007 identified the desire to design and build some infrastructure projects in advance of adequate fees being collected by the City. For that reason, developers have entered into front ending servicing agreements with the City and have constructed work that would normally be funded through the SAF reserve funds. Through these agreements, the developers are entitled to an offset in the form of servicing agreement fee credits that would otherwise be payable. The servicing agreement fee credit concept allows the development community to proceed with new subdivisions without waiting for the City to construct the infrastructure to support the development.

The table below shows the projected servicing fee credits for 2010 to 2014 assuming all credits are used within a five-year period. The projection of front-ended activities and their timing and subsequent redemption of credits, for which there is no historical pattern, contains a high degree of uncertainty.

	<u>Servicing Agreement Fee Credits</u>				
	2010	2011	2012	2013	2014
Balance (Start of Year):	6,130	14,806	11,104	7,403	3,701
Forecast of Credits Earned: (1)	12,377	-	-	-	-
Forecast of Credit Redemptions: (2)	3,701	3,701	3,701	3,701	3,701
Balance (End of Year):	14,806	11,104	7,403	3,701	0

Note:

1. Forecasts all remaining available credits will be earned in 2010.
2. Estimates total net available credits amortized over five years.
3. Developers hold \$6.1M in unredeemed credits at the beginning of 2010 and are eligible to earn a maximum of \$12.4 more before reaching the maximum authorized.
4. As at the beginning of 2010, developers have completed \$8.4M of eligible work for which they have not as yet applied for credit.

Debt Financing

Section 135 of *The Cities Act* creates the authority to issue debt to finance capital projects. While debt is a source of capital financing, ultimately the cost of the debt (principal and interest) has to be funded through the utility operating budget. The following table is a summary of the outstanding debt and the debt maturing each year.

Year	<u>Schedule of Utility Debt Maturities (\$000's)</u>				Total	Per Cent of Total (%)
	<u>Debt Issues</u>					
	\$40 Million Nov 2002	\$6 Million May 2004	\$16 Million June 2009	\$43.1 Million June 2009 (GTH)¹		
2010	4,000	600	906	-	5,506	8.8
2011	4,000	600	906	-	5,506	8.8
2012	4,000	600	906	-	5,506	8.8
2013	-	600	906	-	1,506	2.4
2014	-	600	906	43,100	44,606 ²	71.2
Total	12,000	3,000	4,530	43,100	62,630	100.0

Note:

1. In 2009, debt in the amount of \$42.4 million was reassigned from the GTH to fund the General Utility Reserve. As a result of the reassignment of this debt, no additional debt is required in 2010 to fund the Utility's capital program.
2. The debt reassigned from the GTH is fully due in 2014. In that year, additional debt in the amount of \$30 million will be required to replace a portion of the reassigned GTH debt.

In the 2010 – 2014 Utility Capital Program, debt requirements are:

- \$22.6 million in 2011.
- \$52.0 million in 2012.
- \$45.5 million in 2013.

The Utility model includes funding for debt issuance costs and the repayment of projected debt issues based on a twenty year term and an interest rate of 6%. In 2014, the GTH debt will mature and new debt of \$30 million will be required to replace it.

The future debt requirements are based upon a projected annual utility rate increase of 9% for 2010. The future debt requirements are subject to change, as capital requirements in future years may change, the projected cost of requirements could change, or revenues generated from rate increases may change. In addition to the projected debt required to fund the 2010 – 2014 Utility Capital Program, based on current revenue and expenditure projections in the Utility model, there are additional debt requirements beyond 2014. The following graph shows projected utility debt levels incorporating the existing debt and the projected additional debt for 2010 through 2014.

Utility Debt Projections

